



THE STUDEBAKER DRIVERS CLUB

GREASY PRINTS

A BI-MONTHLY PUBLICATION OF THE ORLANDO AREA CHAPTER
ESTABLISHED OCTOBER 15, 1983 CHARTERED JUNE 19, 1984

Volume 8

Number 3

January 1991

PRESIDENT:	GEORGE MORRILL	1002 WILLA LAKE CIRCLE	OVIEDO	FLORIDA	32765
VICE PRESIDENT:	PAUL WHITE	32404 OKALOOSA TRAIL	SORRENTO	FLORIDA	32776
SECRETARY:	BONNIE CREAMER	3410 S.Nashville St.	ORLANDO	FLORIDA	32809
TREASURER:	ANITA AMBROGIO	1025 NODDING PINES WAY	CASSELBERRY	FLORIDA	32707
ACTIVITIES	LARRY GOLUB	102 WILD PLUM	LONGWOOD	FLORIDA	32779
DIRECTORS:	JERRY SHELTON	1216 7TH STREET	ST.CLOUD	FLORIDA	34769
	LAMONT CHURCHILL	3410 S.Nashville St.	ORLANDO	FLORIDA	32809
MEMBERSHIP:	BARBARA GOLUB	102 WILD PLUM	LONGWOOD	FLORIDA	32779
EDITOR:	MARTHA MORRILL	1002 WILLA LAKE CIRCLE	OVIEDO	FLORIDA	32765

Central Florida Automotive Festival

Floridas Most Exciting Automotive Events!

February 9th-10th, 1991

Marchant Stadium, Lakeland, Florida

Car Show

And

Swap Meet

TOY SHOW—Antique—Farm—Pedal Cars—Trains

Car Show 70 Classes Over 2 Big Days

ROD & CUSTOMS-SAT. ANTIQUE & SPECIAL INTEREST- SUN

HUGH SWAP MEET - Vendors from 25 States

-Over 600 Spaces Sold Out each year-Register Early

CAR CORRAL--Sell Your Car or Truck..No High Auction Fee

Admission \$3.00-Under 6 free..Located on RT 33-Exit 19 off I-4

Show Hours - 7:00 a.m. - 4:00 p.m. Both Days

Register NOW to be included in this years Event

Hotline - (813) 667-0235 (813) 986-6065

Please Check For Which Show

REGISTER NOW ** AVOID LATE FEES

- Cen. Fl. Custom Vehicle Extravaganza -----(Jan. 11-12-13,1991)
- * Cen. Fl. Auto Festival, Lakeland -----(Feb. 9-10,1991)
- Cen. Fl. Auto Festival, Palmetto -----(March 9-10, 1991)

Name _____ Phone _____

Street Address _____

City, State, Zip _____

Inside Vendor Space(10x10) includes 1 Table@\$35.00 _____

Custom Vehicle Show (10x10) Isle space @ \$80.00 _____

Custom Vehicle Show(10x10) corner space @ \$100.00 _____

Outside Vendor Space(12x25)***** @\$30.00 _____

LATE REGISTRATION FEE**ADD \$10.00 per space 2 weeks prior to show

Primary Type Merchandise Sold***Must Be Filled In To Get Space***

Merchandise must be 75% AUTO RELATED to be in Swap Meet Section.
Non-Auto merchandise will be placed in Antique & Craft Section.

CAR SHOW Pre-Registration (Includes Driver & 1 Passenger)

Dash Plaques to Pre-Registered only ***** \$6.00 _____

Day of Show Car Registration ***** \$10.00 _____

FOR OUTDOOR SHOWS ONLY...

If You Plan To Bring Car Both Days, Photo Copy Form, Fee Each Day.

CAR FOR SALE SPACE (no parts for sale)*****\$30.00 _____

YEAR _____ MAKE _____ BODY STYLE _____

MODIFIED? yes ___ No ___ CLASS: SAT. _____ SUN. _____

TOTAL AMOUNT ENCLOSED _____

*****NO ENTRY ACCEPTED WITHOUT SIGNATURE*****

It Is Agreed that all persons who enter for exhibition and competition purposes in the show will abide by the rules set forth by the show management. It is also agreed that neither the show producer, nor the owner of the grounds in which the show is held, shall be responsible to me for any damage to, or theft of any part of my entry or display.

SIGNED _____

Please make checks payable to Central Florida Automotive Festival

- 1-Fords 1897-1927
- 2--1897-1927 (except Fords)
- 3--Fords 1928-1931
- 4--Fords 1932-1942
- 5--1928-1942 (except Fords)
- 6--1946-1951 (all makes)
- 7--Fords 1952-1960
- 8--GM Prods. 1952-1960 (except 55-57 Chevy)
- 9--1952-1960 (except Ford & GM)
- 10-1955-1956 Chevy
- 11-1957 Chevy
- 12-Mustang 64-68 (converts.)
- 13-Mustang 64-68
- 14-Shelby & Boss Mustangs
- 15-Mustang 1969-1981 (all)
- 16-Mustang 1982-present
- 17-Corvette 1953-1967
- 18-Corvette 1968-present
- 19-Thunderbird 1955-1957
- 20-Thunderbird 1958-present (converts.)
- 21-Thunderbird 1958-present
- 22-Corvair 1960-1969
- 23-Camaro & Firebird 1967-1969
- 24-Camaro & Firebird 1970-present

SUNDAY

- 25-Chevelle, Buick Gran Sport & Skylark 64-74
- 26-GTO, Tempest, Lemans, 442, Cutlass 64-74
- 27-MOPAR Performance 1964-1974
- 28-El Camino & Ranchero (all)
- 29-1961-1964 (not classed above)
- 30-1965-1969 (not classed above)
- 31-1970-1974 (not classed above)
- 32-1975-present (not classed above)
- 33-Trucks thru 1948
- 34-Trucks 1949-1964
- 35-Trucks 1965-present
- 36-Volkswagons
- 37-Foreign (English)
- 38-Foreign(except English)
- 39-Motorbikes (small cc)
- 40-Motorcycles
- 41-Special Interest thru 1948
- 42-Special Interest 1949-present
- 43-Special Interest Trucks

LAKELAND -PALMETTO Schedule

Sat. & Sun.
Show Car Set-Up 7am.-10am.
(no cars allowed after 10am.)
Trophy Presentation 4pm
Trophies 1st,2nd,3rd each class
Best of Show each day
Peoples Choice each day

Mailing Address

Central Florida Automotive Festival
12101 U.S.301 North-#319
Thonotosassa, FL.33592

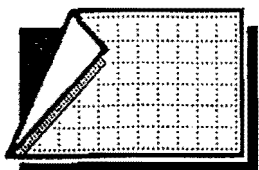

HEADLIGHTS: *THE ROAD AHEAD*

GREASY PRINTS

CALENDAR OF EVENTS

REGULAR MEMBERSHIP MEETINGS: 7:00 PM, 2nd Saturday of each month at Sanford Motor Co. 3418 S.Orlando Dr. (17-92) Sanford, Florida (1/2 mile north of Lake Mary Blvd).

CHAPTER BREAKFASTS: 8:00 AM, last sunday of each month at Frisch's Big Boy 605 Lee Road Orlando, Florida (just west of I-4, formerly Howard Johnsons), Bring Your Old Baker (BYOB)

DECEMBER 1990

- 08 REGULAR MEMBERSHIP MEETING 7:00 pm at Sanford Motors Inc. (see address above). Cruise to Wendys after the meeting.
- 30 Breakfast at 8:00 am. Frisch's Big Boy 605 Lee Road Orlando, Florida (just west of I-4)

JANUARY 1991

- 12 REGULAR MEMBERSHIP MEETING 7:00 pm at Sanford Motors Inc. (see address above). Cruise to Wendys after the meeting.
- 27 Breakfast at 8:00 am. Frisch's Big Boy 605 Lee Road Orlando, Florida (just west of I-4)

FEBRUARY 1991

- 09 REGULAR MEMBERSHIP MEETING 7:00 pm at Sanford Motors Inc. (see address above). Cruise to Wendys after the meeting.
- 24 Breakfast at 8:00 am. Frisch's Big Boy 605 Lee Road Orlando, Florida (just west of I-4)

MARCH 1991

- 09 REGULAR MEMBERSHIP MEETING 7:00 pm at Sanford Motors Inc. (see address above). Cruise to Wendys after the meeting.
- 31 Breakfast at 8:00 am. Frisch's Big Boy 605 Lee Road Orlando, Florida (just west of I-4)

APRIL 1991

- 13 REGULAR MEMBERSHIP MEETING 7:00 pm at Sanford Motors Inc. (see address above). ELECTION OF NEW OFFICERS WILL TAKE PLACE AT THE END OF THE MEETING. Cruise to Wendys after the meeting.
- 28 Breakfast at 8:00 am. Frisch's Big Boy 605 Lee Road Orlando, Florida (just west of I-4)

MAY 1991

- 11 REGULAR MEMBERSHIP MEETING 7:00 P.M. at Sanford Motors, Inc.
- 26 Breakfast at 8:00 A.M. Frisch's Big Boy (see address above)

JUNE 1991

- 08 REGULAR MEMBERSHIP MEETING (same as above)
- 24-29 SDC International Meet, Springfield, MO
- 30 Breakfast at 8:00 A.M. Frisch's Big Boy



Mark your calendars for:

February 9-10, 1991 Central Florida Automotive Festival Car Show and Swap Meet.

March 1-3, 1991 Keystone Swap Meet.

4TH ANNUAL CHRISTMAS DINNER

by Frank Ambrogio - MD (Mystery Diner)

This years Orlando Area Chapter's Christmas diner was held on sunday, the 16th of December, at Chris's House of Beef on John Young Parkway, just north of highway 50 in Orlando.

The attendees included Jeff & Lou Elliott and Uncle Bill (Beeel), Leroy & Leta Long, George Morrill, Wayne & Dee Newberry, Larry & Barbara Golub, Frank & Anita Ambrogio, our guests Don & Evelyn Bales, Paul & Marion White, Paul & Barbara Parker (who came all the way from Inglis, Fl.), John & JoAnn Gormican & their guests (whose names I have forgotten, sorry), and Bill & Diane Pelick.

It was a beautiful day for taking the Studebaker out for a ride and Chris's House of Beef proved to be an excellent choice for our dinner. The accomodations were artistic, the beverages were bountiful, the chairs were comfortable, the dining was delightful, the environment was enchanting, the food was fantastic, the greeting was gay, the hostess was happy, the linens were lovely, the napkins were neat, the parking was plentiful, and the service was super. I don't know why, but for some strange reason I kept wanting to order alphabet soup (that was the corn).

Everyone seemed to enjoy it and I didn't hear any complaints, so I have to assume the event was a success. The menu left everyone with a wide choice of selections in a wide range of prices and the real food lovers, could go to the food bar and fill their plate as often as

they liked

I'm all for a return engagement next year unless someone thinks of another place. If not, mark December 15, 1991 on your calendar.

Thanks to Barbara Golub for making the arrangements.

HAPPY BIRTHDAY

CHRISTINA	CADE	1212
STU	CHAPMAN	1222
LOU	ELLIOTT	1213
GEORGE	FAVOR	1212
HELEN	GESSNER	1218
DEAN	GESSNER	1201
BARBARA ANN	GOLUB	1223
JANDI	MORGAN	1209

HAPPY ANNIVERSARY

LEROY & LETA LONG	1227
-------------------	------

Birthday announcements



HAPPY BIRTHDAY

JAMES M.	BAILEY	0131
STEPHEN A.	CADE	0107
JEROLD R.	CADE	0128
JOSEPH C.	LATCHAW	0107
SANDY	MORGAN	0128
KARICK A.	PRICE JR.	0108
ALBERTO	SANCHEZ DE FUENTES	0129

HAPPY ANNIVERSARY

STEPHEN & WENDE CADE	0117
LEROY & HELEN GESSNER	0126
BILL & LOIS MCDOWELL	0125
THE SANCHEZ DE FUENTES FAMILY	0102
PAUL & MARION WHITE (RR)	0108



Anniversary announcements



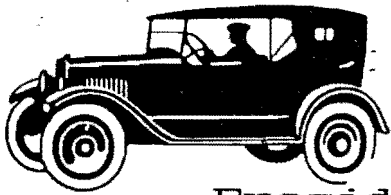

President's Corner

The cool weather brings out the Studes. At the last breakfast there were four Studebakers in Frisch's parking lot. The Christmas dinner also brought out four.

I decided to drive my Avanti to the Christmas dinner. My faithful stude which I had driven daily for two years failed me when it was time to leave. I was about to be left stranded at home on the opposite side of Orlando from the dinner location. With careful coaxing it started and maded it to and from dinner.

I thought the installation of a new starter solenoid would cure the problem, but as I attempted to leave for work it failed to start again. After further experimenting, I found that the new solenoid which had functioned when first installed, now wanted to be grounded in order to function (another mystery of the fiberglass wonder).

Back to the Stude driving, let's keep being seen in those marvelous machines. A fine opportunity will be the February show in Lakeland.

George

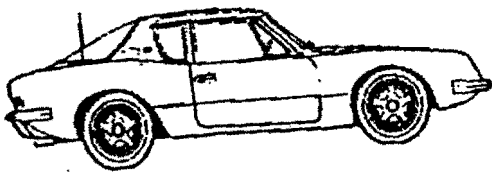

MINUTES OF THE REGULAR MEMBERSHIP MEETING

December 8, 1990

The meeting was called to order at 7:20 p.m. by President George Morrill. Members attending: Leroy and Leta Long, John and JoAnne Gormican, Jeff and Lou Elliott, Frank and Anita Ambrogia, Paul and Marion White, George and Martha Morrill, Dr. Cade and Stephen Cade, Bonnie Creemer and Lamont Churchill.

Greasy Prints

The next breakfast meeting will be Dec. 30th, at Frisch's Big Boy on Lee Road. Larry and Margie Long of Ontario, Canada, joined us for our last breakfast. So nice to get to meet them.

Stephen Cade gave us an up-date on the plans for the 1991 State Meet. He had checked with several more hotels and after much discussion, it was decided to have the State meet at Howard Johnson's and the banquet across the street at the Holiday Inn. It will take place the last weekend of October, (25-26-27).

The **Mississippi Mud** Lark is to be the car for the drawing. A black '63 Lark from Mississippi.

Frank will send post cards to all registered club members in Florida in reference to the State meet. Paul wrote to Turning Wheels to inquire about what type of advertising is available to the Chapter.

Activities suggested: Lakeland Car Show in February. We would like to meet and caravan together. It was suggested that we get with Central Florida Chapter.

Old Spanish Sugar Mill in DeLeon Springs State Recreation Area. This is where you cook your own pancake breakfast. It was thought March might be a good time for this.

50-50 drawing was held. Stephen Cade was the winner. \$7.00 for the winner and \$7.00 for the Chapter.

Meeting adjourned, followed by refreshments & Happy Birthday to Lou Elliott. Respectfully Submitted: Bonnie Creemer

FRANK(LY) SPEAKING

by Frank Ambrogio

In December of 1986, Paul & Marion White met Anita and me for breakfast at the former Friendly's Restaurant in Sanford. We drove our Studebakers and had an enjoyable time together. After breakfast, we stood around in the parking lot, braving the cold winds, and continued to discuss the Orlando Area Chapter and look at each of our cars. I had always felt that a Chapter breakfast each month would be a great way to get together and enjoy each other's company and get our cars out of the garage.

In February 1987, the Baker Breakfast Bunch began to meet for breakfast on the last Sunday of the month. The last Sunday seemed like a good day as it fell midway between our regular monthly meetings. This enabled us to meet twice a month and allow members who could not make the meetings a second chance to get together with fellow Chapter members.

Sunday morning is a great time to take the Studebaker out for a drive. The weather is still cool and there is very little traffic. We decided to rotate our breakfast sites among 4 Friendly's Restaurants in various sections of the area in order to try to make it convenient for a different group on any given last Sunday.

The event was slow to catch on and on more than one occasion, especially during the summer, the turnout consisted of Dave Straughn and the Ambrogios. We decided to keep on with the schedule and pretty soon we had a good core of regulars attending.

In 1989, one by one, the Friendly's Restaurant began closing and some were reopened as Perkins Restaurants. During this transition period, it was decided to try to find one central location and meet there each month. We decided on Angel's Restaurant as this is the same place the AACA Florida Region meets on the first Sunday of each month. Angel's proved to be a fine setting with great parking and a room where we could all sit together (something we couldn't do at Friendly's). After about 5 months at Angel's, several members complained that the prices were a bit excessive and we eventually moved to our present meeting site, Frisch's Big Boy on Lee Road just West of I-4. At Frisch's, we each have the option of ordering from the menu or serving ourselves from the breakfast bar.

In recent months, our turnout has been very good with some members and guests arriving from Gainesville, Inverness, Christmas, Odessa and Hamilton (Ontario). The winter time seems to bring out the appetites in our members and this winter we have been stuffing Frisch's and our stomachs to excess.

It does my heart good to see so many of our members turning out for a Chapter activity, especially one which takes absolutely no planning or coordinating. All you have to do is simply show up and eat. It adds a little more fun if you also Bring Your Old Baker (BYOB).

The Central Florida Automotive Festival will be taking place on Feb 9-10 at Marchant Stadium in Lakeland. At our December meeting, we discussed the possibility of our Chapter making a day of it by driving our Studebakers and entering them in the show on Sunday the 10th. This day is reserved for stock production vehicles, which covers most of our member's cars. There will be 43 judging classes with separate classes for Chevys, Fords, GM products, Thunderbirds, Mustangs, MOPAR, etc. and dash plaques will be given to those who pre-register.

This is a great chance to give your Studebaker a chance to show its stuff on the highway and the show field and to let others in the area know that there really is an interest in Studebaker in Central Florida. Check the calendar for details.

SAVE THAT GRILLE SHELL! If you have ever had to find a replacement grille shell for your GT you know they are rare and expensive. There are two things I would like to point out to GT owners in hope that they may save their grilles. First, **DO NOT OVER TIGHTEN THE MOUNTING BOLTS!!** The grille metal is very soft and thin and over-tightening them causes dimples to appear on the outer surface. If you ever have the car repainted I would remove and replace the grille yourself. You should look at the outer grille shell surface while tightening to make sure that they don't dimple.

The other precaution is that many GT's front springs have sagged and, consequently, lower the front ride height. The danger here is that many modern cars have much higher bumper heights than they did in the sixties and when they parallel park in front of your car their bumper runs right into your precious shell.

One common oversight I see on many GTs is that the flat black areas behind the grille are left body color after repainting. Studebaker painted the areas behind the grille shell and the inner surface of the lower air scoop flat black. This is especially noticeable on light colored cars.

REPAIRING STEERING WHEELS

Steering wheel cracks are easily repaired with a minimum of cost and labor. There is a two part epoxy called PC-7 and is available from Eastwood or it can be found at some hardware stores.

First, take a hacksaw and cut the cracks all the way down to the wire frame. Then you mix equal amounts of the two part epoxy and completely fill the gap. Leave a little extra material over the repair. The epoxy hardens very slowly usually in 1 to 2 days. After it hardens file the excess down to it's almost flush and use sand paper for final contouring. The wheel can now be primed.

Answers to Studebaker Circle-A-Word November 1990

SKYHAWK
DICTATOR
PRESIDENT
POWERHAWK
DRAIN
SILVER HAWK
RAGTOP
ADS
AGED

PURE
AVANTI
REGAL
GREASY
FRINT
AGED
SEDAN
ORLANDO
REST

FIRES
TWO DOOR
WAGONAIRE
ORLANDO
SPEEDSTER
GOLDEN
EXPRESS

STUDEBAKER'S CIRCLE-A-WORD (by N. Latchaw -1990)

Circle the letters either diagonally, across, or backwards to find the words below:

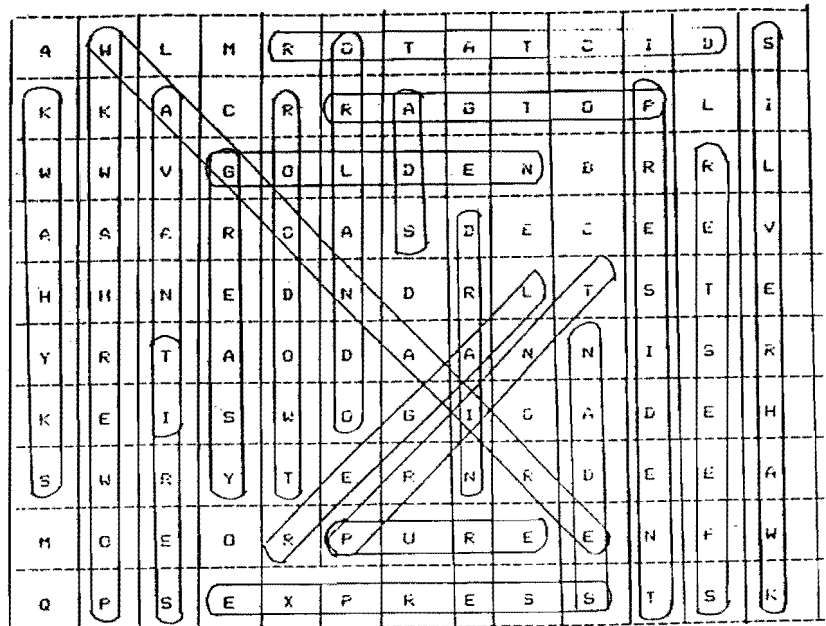

SEARCHLIGHTS:

CLASSIFIED ADS

Ads are free to members and run for 2 issues. Please include the city and the area code if a phone number is given. Deadline for ads are the 20th of the month preceding publication.

For Sale

Studebaker Avanti '64

A real labor of love! R1, Round headlights, automatic transmission, power steering, power brakes, A/C, new brake rotors, brand new dash pad, AM radio, completely rebuilt front-end, new front seats. Driven daily to work for two years. Painted white. Many extra parts, manuals which will be negotiated with price. **\$8,500**. Call George Morrill, (407) 365-4935

Wanted

- a. T-85 Transmission with Overdrive
 - b. 55 Coupe hood, any condition.
 - c. Serviceable V-8 Front Brake Drums
- Studebaker parts only

Bill Hahn P.O. Box 10312, Daytona Beach
Florida 32017 904-255-6093 5-7:30 p.m.

1962 Champ Six W/OD, 17,000⁰⁰ miles. Recent lacquer paint and rad. None finer anywhere!: \$6500 Paul White (904) 383-7279

SOLD

Editors Note: Is there anyone out there who would like to sell or buy Studebaker parts or other automobile items. Please send to address on front of newsletter. Thanks.

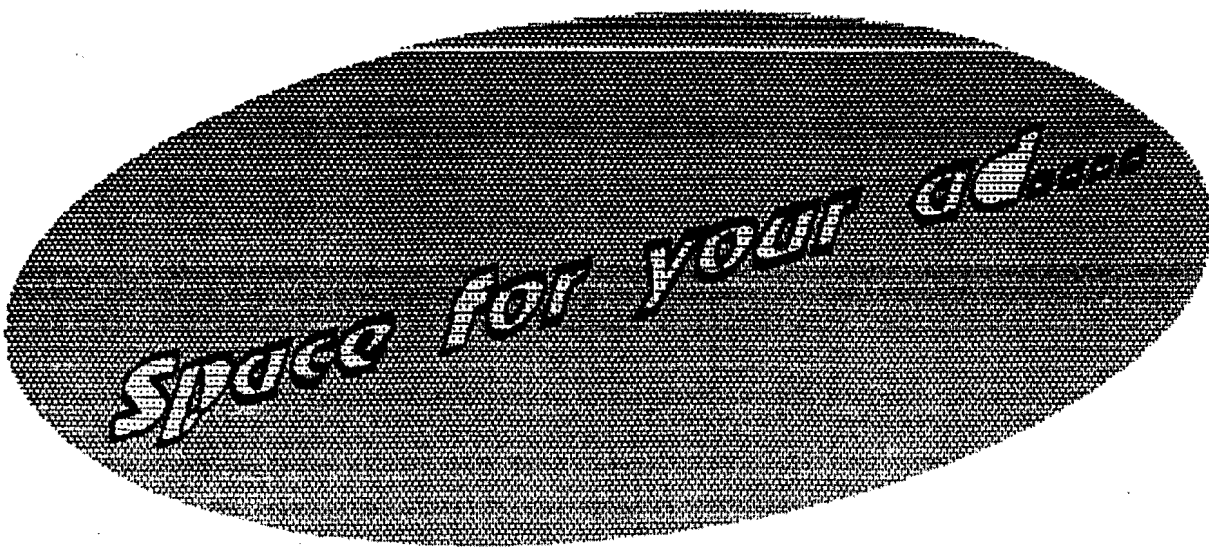

SANFORD MOTOR CO., INC.

3418 S. Orlando Dr.
SANFORD, FLORIDA 32773



Cherokee Comanche - Wrangler Wagoneer - Premier Medallion - Summit

DONALD J. BALES
President

Bus. Phone (407) 322-4382
Bus. Phone 321-0871

Paint & Body

Stainless Steel

Ted's
Classic Car Restorations

Ted Janowski
(904) 774-5512

2661 San Juan St.
DeLand, FL 32724



PACKARD FARM

Studebaker - Packard
Parts and Accessories
Large Inventory of Rubber Products
We Buy Toy Tractors

97 N. 150 W.
(Road 150 W. & U.S. 40)
Greenfield, IN 46140

BILL McDOWELL
(317) 462-3124

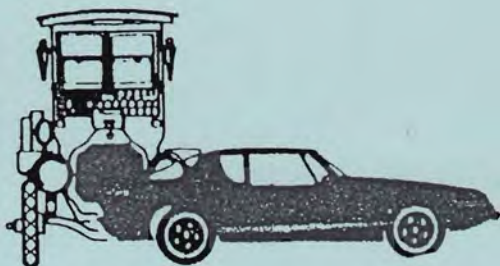

Larry R. Dudley

American
Speedy Printing
Maitland Center



(305) 682-5854

998 Lake Destiny Road
Altamonte Springs, FL 32714

AVANTI * LARK * HAWK
STUDEBAKER PARTS & REPAIR

R1
R2
R3
R4

SPECIALIZING IN
HARD TO GET PARTS
PERFORMANCE PARTS



MYER'S STUDEBAKER PARTS

JON B. MYER
3842 BLEDSOE AVE.
LA, CA 90066

AOA
SDC OEC
(213) 398-1947

Ed Reynolds

(213) 435-0157

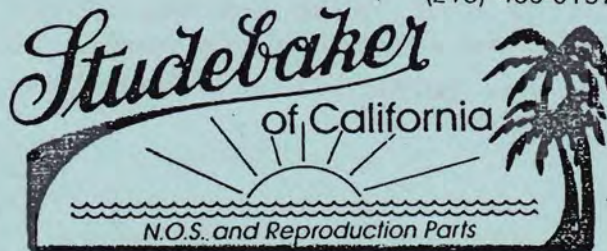

1400 Santa Fe Ave. Long Beach, CA 90813



PHIL'S STUDEBAKER
818 Berlin
Mishawaka, IN 46544

(219) 255-3916

N.O.S. and Excellent Used Parts

Special Interest Autos of St. Louis, Inc.

PH. 314-279-1280

MAIL:
P.O. Box 944
ST. CHARLES, MO 63302

SHIPMENTS:
#5 CHALIN
ST. PETERS, MO 63376

HOURS: MON.-FRI. 8 A.M.-6 P.M.
SAT. 8 A.M.-NOON

Avanti

Avanti



Studebaker

THE STUDEBAKER DRIVERS CLUB ORLANDO AREA CHAPTER

MEMBERSHIP REGISTRATION FORM DUES \$10.00 PER YEAR (DUE AND RENEWABLE OCT 1)

(NEW MEMBERS, SEE SCHEDULE BELOW) MAKE CHECKS PAYABLE AND MAIL TO:

ORLANDO AREA CHAPTER - SDC 1025 NODDING PINES WAY CASSELBERRY, FL 32707

NAME _____ BIRTH DATE (MONTH/DAY) _____

SPOUSE _____ BIRTH DATE (MONTH/DAY) _____

ANNIVERSARY DATE (MONTH/DAY) _____

ADDRESS _____

CITY _____ STATE _____ ZIP _____

HOME PHONE _____ WORK PHONE _____

STUDEBAKER OR STUDEBAKER RELATED VEHICLES OWNED

YEAR	NAME	MODEL	BODY STYLE
_____	_____	_____	_____
_____	_____	_____	_____
_____	_____	_____	_____

NEW MEMBER DUES SCHEDULE (PAY AMOUNT INDICATED FOR THE MONTH YOU JOIN)

OCT - \$10.00 NOV - \$10.00 DEC - \$10.00 JAN - \$9.00 FEB - \$8.00 MAR - \$7.00
 APR - \$6.00 MAY - \$5.00 JUN - \$4.00 JUL - \$3.00 AUG - \$2.00 SEP - \$1.00

To join the ORLANDO AREA CHAPTER, you must be a member of the STUDEBAKER DRIVERS CLUB. Dues are \$18.00 per year. Send name, address, phone number to :

S.D.C. NATIONAL OFFICERS 1990-1991

- President - George D. Krem, 1248 Esther Court, Iowa City, Iowa 52240
- Vice President - Denny Lockmon, 9331 Polk Street, Omaha, Nebraska 68127
- Secretary - Linda Costell, 5831 Balfour Road, Sylvania, Ohio 43560
- Treasurer - Colin D. Fort, P.O. Box 1204, La Jolla, California 92038

P.O. Box 28788, Dallas, Texas. 751228-0788. (1-800-527-3452)

The Studebaker Drivers Club, Inc.



Orlando Area Chapter
 1002 Willa Lake Circle
 Oviedo, Florida 32765

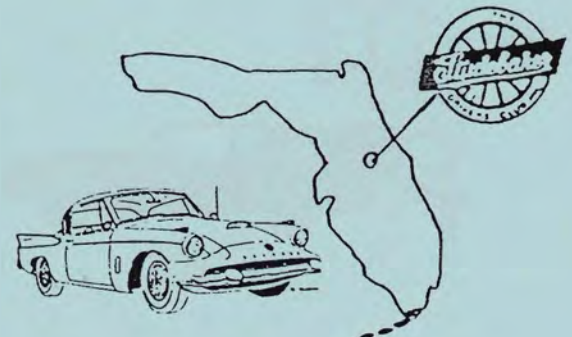



THE STUDEBAKER DRIVERS CLUB

GREASY PRINTS

A BI-MONTHLY PUBLICATION OF THE ORLANDO AREA CHAPTER
ESTABLISHED OCTOBER 15, 1983 CHARTERED JUNE 19, 1984

Volume 8

Number 4

MARCH APRIL 1991

PRESIDENT:	GEORGE MORRILL	1002 WILLA LAKE CIRCLE	OVIEDO	FLORIDA	32765
VICE PRESIDENT:	PAUL WHITE	32404 OKALOOSA TRAIL	SORRENTO	FLORIDA	32776
SECRETARY:	BONNIE CREEMER	3410 S. NASHVILLE	ORLANDO	FLORIDA	32809
TREASURER:	ANITA AMBROGIO	1025 NODDING PINES WAY	CASSELBERRY	FLORIDA	32707
ACTIVITIES	LARRY GOLUB	102 WILD PLUM	LONGWOOD	FLORIDA	32779
DIRECTORS:	JERRY SHELTON	1660 CASSIDY DRIVE	ST.CLOUD	FLORIDA	34771
	LAMONT CHURCHILL	3410 S. NASHVILLE	ORLANDO	FLORIDA	32809
MEMBERSHIP:	BARBARA GOLUB	102 WILD PLUM	LONGWOOD	FLORIDA	32779
EDITOR:	MARTHA MORRILL	1002 WILLA LAKE CIRCLE	OVIEDO	FLORIDA	32765

JOIN THE FUN STUDEBAKER OUTINGS !!

Pancake Breakfast



Poker Run



See Calendar for details

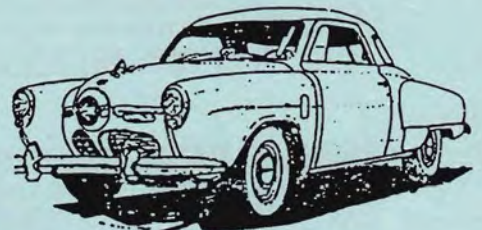
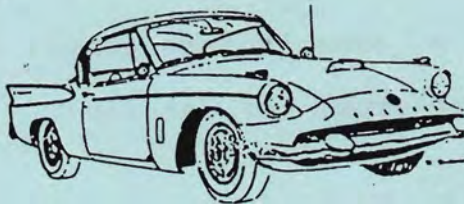

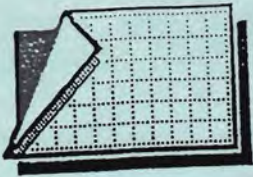

HEADLIGHTS: THE ROAD AHEAD

CALENDAR OF EVENTS

REGULAR MEMBERSHIP MEETING: TIME: 7:00 p.m. WHEN: 2ND Saturday of each month. WHERE: Sanford Motor Co., 3418 S. Orlando Dr. (17-92), Sanford, Fa. (1/2 mile north of Lake Mary Blvd.)

CHAPTER BREAKFASTS: TIME: 8:00 A.M. WHEN: Last Sunday of each month. WHERE: Frisch's Big Boy, 605 Lee Road, Orlando, Fa. (just west of I-4, formerly Howard Johnsons), Bring your own Baker, BYOB

MARCH

- 01-03 BIG DADDY'S AUTOGANZA Auction, Show, Swap!
Don Garlitz Museum of Drag Racing, 13700 S. W. 16th Ave. Ocala, Fa. 32676 1-800444-6468.
- 09 GOLDENROD FESTIVAL 13TH Classic Car Show. Barnett Bank Parking area. Aloma Ave. Goldenrod. Contact Gary Verdino 671-2739 (evening)
- 09 REGULAR MEMBERSHIP MEETING: TIME: 7:00 p.m. see address above -
Cruise to Wendys after meeting.
- 17 OLD SPANISH SUGAR MILL PANCAKE BREAKFAST, WHERE: DeLeon Springs. (See Presidents Note and Minutes for details)
- 23-24 2nd ANNUAL DAYTONA SPEEDWAY SPECTACULAR, Daytona Speedway.
Admission \$6.00, Rick D'Louhy 904-255-7355
- 29-31 EARLY IRONS EASTER ROD RUN. Holiday Inn, University and Alafaya trail.
- 31 OAC CHAPTER BREAKFAST 8:00 A.M. (See above for details)

APRIL

- 06 RESTORATIONS 91' car show swap. Longwood Village, Hwy 434 Sponsored by Florida Region AACA.
- 13 REGULAR MEMBERSHIP MEETING: TIME: 7:00 p.m. (see address above) ELECTION OF NEW OFFICERS WILL TAKE PLACE AT END OF MEETING.
- 21 ORLANDO AREA CHAPTER SPRING INVITATIONAL ROAD TOUR - POKER RUN.
Open to all antique/special interest automobiles. See front page for registration and information.
- 27 15TH ANNUAL HERITAGE CLASSIC sponsored by: Volusia region AACA at Riverfront park, Daytona Beach. For info. Dorothy Brindley, 423 Plumosa Ave. Harbor Oaks, Fl 32127.
- 28 OAC CHAPTER BREAKFAST 8:00 a.m. (see above for details)

MAY

- REGULAR MEMBERSHIP MEETING: TIME 7:00 p.m. (see address above)
Cruise to Wendys after meeting.
- 26 OAC CHAPTER BREAKFAST 8:00 a.m. (See above for details)
- June
- 08 REGULAR MEMBERSHIP MEETING: 7:00 p.m. (see address above) Cruise to Wendys after meeting.
- 24-29 SDC INTERNATIONAL MEET Springfield, Missouri (see turning Wheels for more information)
- 30 OAC CHAPTER BREAKFAST 8:00 a.m. (See above for details)

JULY

- 13 REGULAR MEMBERSHIP MEETING: 7:00 p.m. (see address above) Cruise to Wendys after meeting.
- 28 OAC CHAPTER BREAKFAST 8:00 a.m. (See above for details)

AUGUST

- 10 REGULAR MEMBERSHIP MEETING: 7:00 p.m. (see address above) Cruise to Wendys after meeting.
- 25 OAC CHAPTER BREAKFAST 8:00 a.m. (See above for details)



THE ORLANDO AREA CHAPTER OF THE STUDEBAKER DRIVERS CLUB
PRESENTS



A SPRING INVITATIONAL ROAD TOUR / POKER RUN

OPEN TO ALL ANTIQUE AND SPECIAL INTEREST AUTOMOBILES



APRIL 21, 1991

Trophies will be awarded for 1st through 5th places.

Registration will be from 10:00 A.M. to 11:00 A.M. Registration will be held at the Sanford Motor Company, Jeep/Eagle dealership appx. 1.5 miles north of Lake Mary Blvd on Hwy. 17-92. First car will leave at 10:30 A.M., last car out will be at 11:00 A.M. Last car in at end of run will be 1:00 P.M.

Registration at the door is \$5.00. Pre-registration is \$3.00. (Fee is per person drawing a poker hand. All passengers can participate.)



For more information contact:

Gregg Case at (407) 841-2918 or
363-2128



****BRING YOUR PICNIC BASKET FOR A PICNIC LUNCH AND TIRE KICKING****

PRE-REGISTRATION FORM

NAMES: _____

CAR MAKE: _____

HOME ADDRESS: _____

CITY: _____ STATE: _____ ZIP: _____

PHONE #: _____ CLUB AFFILIATION: _____

Mail To:



Anita Ambrogio
1025 Nodding Pines Way
Casselberry, FL 32707



2-A

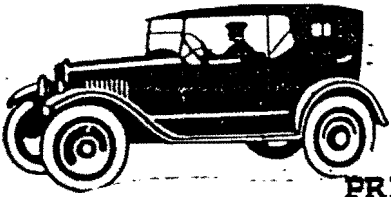

PRESIDENT'S CORNER

MINUTES OF THE REGULAR MEMBERSHIP MEETING
January 12, 1991

Meeting was called to order by President George Morrill.

March and April bring two extra chances to back the old Baker out of the garage and show it off. March 17 we have planned an outing to the restaurant at DeLeon Springs State Park. The fare will be pancakes cooked on a grill in the middle of the table. We have been told that it is a very popular spot to eat and if the difficulty with getting a reservation is any indication of this, we agree. The only available time is 8:00 AM or 12:00 noon. After many phone calls and much concern over the earliness of the hour we chose the 8:00 a.m. slot. Although it means leaving in the wee hours of the morning, it will allow you to have the rest of your Sunday for a ride in the country in your Studebaker. Read on for details of the event...

March 17, Sunday **PANCAKE BREAKFAST**
Meet at Stuckey's at I-4 and State Road 46 by 7:00am Plan on leaving for the Resturant by 7:10 a.m. Please join us for an enjoyable morning. We have made reservations for 20.

Another great event in April is the *Road Tour-Poker Run*. New member Gregg Case has offered to set up the rally laying out the course. Cards are drawn at several check points. Trophies will be awarded based upon the best poker hands. See registration form, backside of front page for further details.

Be sure to attend the April Chapter meeting, we will be holding chapter elections for the next years officers. If you would like to participate as club officer, please feel free to volunteer for nomination to any of the officer positions.

George

Members present (25 total !!) Jeff & Lou Elliott - Jerry & Cindi Shelton - John & Joann Gormican - Leroy & Lela Long - Frank & Anita Ambrogia - Paul & Marion White - Hy & Jackie Berman - Stephen & Wendy Cade - George & Martha Morrill - Bonnie Creemer & Lamont Churchill - Larry & Barbara Golub - Leroy & Dean Gesener, and Wayne Newberry.
New Members: A warm welcome to our new members who joined tonight! Greg and Kim Case.

Frank has mailed information regarding meetings to TURNING WHEELS. The price for mailing labels from National is \$15.00, it was agreed to purchase these for us regarding the STATE MEET.

Paul said he has received no response from Turning Wheels regarding information for display ads. He has asked for this again and has sent information to What's Happening.

Registration for State Meet: Paul moved that we have :\$3.00 for general registration fee. \$5.00 for 1st care, \$3.00 for second care. Additional care free. Marion seconded and passed.

It was moved and seconded that we include Packards on the registration form. Discussed and approved.

Banquet ticket is to be your chance on the drawing for the "Mississippi Mud Lark".

Activities: Sunday Feb 10th, Lakeland Car Show. set-up is from 7:a.m.-10 a.m. We will meet 8:a.m. at the I-4 Rest area close to Disney Exit and Caravan down. Those taking a different route will meet us at the show.

Stephen announced that Poor Bill from Packard Farms is now making windshields and rear window seals. These are a lot better then what has been available

Respectfully submitted: Bonnie Creemer

MINUTES OF THE REGULAR MEMBERSHIP MEETING
February 9, 1991

Birthday announcements

COREY	BERMAN	0329
DOUG	CHAPMAN	0330
LAMONT	CHURCHILL	0321
BONNIE	CHURCHILL	0313
RICHARD L.	LATCHAW	0307
ALEXANDER	LATCHAW	0314
CAREY ANN	MORGAN	0310
WAYNE	NEWBERRY	0322
BARBARA	PARKER	0307
JERRY	SHELTON	0329
CINDI	SHELTON	0321
MARION E.	WHITE	0305



HAPPY ANNIVERSARY
GEORGE & MARTHA MORRILL 0330



HAPPY BIRTHDAY

GEDNEY	BARTEN	0408
JEFF	ELLIOTT	0420
OSCAR	KOBERG	0420
SUE	LAYMAN	0408
GEORGE A.	MORRILL	0406
SONI	PILKINGTON	0418
DWIGHT	SWANSON	0406

HAPPY ANNIVERSARY
LARRY & BARBARA GOLUB 0402



Anniversary announcements



**GET WELL WISHES
FOR JACKIE BERMAN**

Jackie recently had major surgery to remove a rather large tumor from her kidney. She is now recuperating at home. If you would like to drop her a card, the address is:

76 S. Halifax Drive
Ormond Beach, Fl. 32176



Meeting was called to order by President George Morrill.

Members present: (17 total) Stephen & Wendy Cade - Leroy & Lela Long - Jeff & Lou Elliott - Jerry & Cindi Shelton - Frank & Anita Ambrogio - Bonnie Creemer & Lamont Churchill - John & Joann Gormican - George Morrill - Scott Piloian, Paul White.

Announcements: Breakfast meeting Feb. 24th and next regular meeting is March 9th.

Minutes of meeting were read and approved. Treasurer reported a balance of \$1385.00

Activities: March 17th was suggested as the date for the trip to the Old Spanish Mill in DeLeon Springs State Recreation Area. We will plan on a caravan from Stuckeys on I-4 and rt. 46. Times will be decided and posted in future calendars and notices.

State Meet Update. Frank said he wondered if the low percentage of response (approx 5% last time) warranted the cost of sending flyers to all registered S.D.C members in Florida (approx. 360). We got much better results sending information to the chapters. (about 150 members). Cost of flyers: mailing 350 flyers @29 each= \$79, printing \$26.00 labels \$15.00 for a total of \$114.00. Several options were discussed. 1. Send flyers to all Fl. members and chapters. 2. Send flyers to Florida members within 200 miles and chapters, or 3. Send flyers to chapters only. No action taken at this time.

Letter from Ozark Trails chapter asking if we want to sponsor a trophy for 1991 National Meet. Cost is \$60.00 each class. Anita moved we sponsor a trophy class and Lamont seconded it. Motion passed.

March breakfast will fall on Easter Sunday. No one objected so it will remain the same.

Show and Tell: Paul has band hats and was hoping we could get up a band for State Meet. 50-50 drawing was won by Cindi \$7.00 for winner and club.

Meeting adjourned for coffee and refreshments.

Respectfully submitted

Bonnie Creemer

SEARCHLIGHTS:**CLASSIFIED ADS:**

Ads are free to members and run for 2 issues. Please include the city and area code if a phone number is given. Deadline for ads is the 20th of the month preceding publication

For Sale**Parts:**

2b1 carb, 6cyl water and fuel pumps,
starters, generators,
55 front bumper,
pair N06 coil springs,
used '64' Curieer doors,
55' speedometer,
53' Land Cruiser window visors,
N06 59-60 hood ornament,
used '64 convertible door
complete with glass and trim,
used '63 trunk lid,
new 10 1/2 inch clutch disk,
57-58 heater core - good used,
V8 fuel pump and distributor cap
Paul White (904) 383-7279

Wanted

1941 President or Commander.
Prefer Coupe, will consider others.
No Basket Cases
Paul White (904) 383-7279

For Sale:

Transmissions: 1 T86E with OD, 1
Truck N2 Automatic
Trim: Most Stainless for '55
Sedan, quarter top Stainless for
Coupe.
Engine: 64-V8 Running, Rebuild-
able, Hear it Run, Very Reasonable
Paul White (904) 383-7279

Studebaker Avanti '64
R1, Round headlights, automatic
transmission, power steering, power
brakes, A/C, new proke rotors, new
dash pad, AM radio, completely
rebuilt front end, Driven daily for
two years. Parts and Manuals.
Daughter headed for University of
Alabama, need funds for tuition. \$7,500
Call George Morrill
(407) 365-4935.

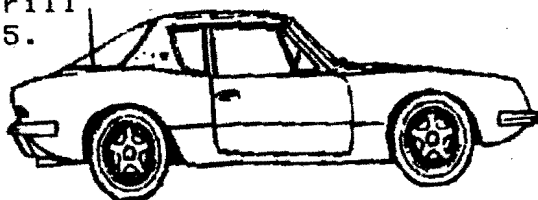
**PARTS BINS**

Making use of those empty plastic oil bottles, by cutting them in-two to the height that will fit into a drawer or cardboard box.

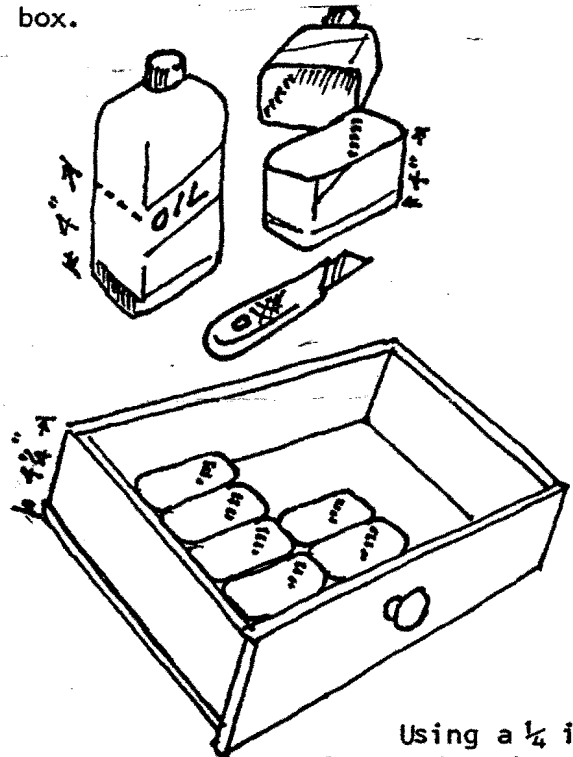
**T
E
C
H
T
I
P**

Using a 1/4 inch riser under the oil bottle will allow enough space for the drawer to slide into it's space without hanging-up. With the riser in place, then using a laundry marking pen, use the edge of the drawer or box, mark the bottle all the way around, then using a utility knife cut the marked line. Wipe out any oil and you are now ready to separate those small items.

Taken from THE DISTRIBUTOR
Vol 17 Feb/Mar. 1991

newsletter Feb Ad

Hy Berman ad
1964 Commander 2 door complete
restored 5 years ago. 6 cylinder engine
needs repainting. new engine out of
crate 5 years ago. new interior
call Hy Berman. 904-672-8542 negotiate
3500

NOTES. CRP

SANFORD MOTOR CO., INC.

3418 S. Orlando Dr.
SANFORD, FLORIDA 32773



Cherokee Comanche - Wrangler - Wagoneer - Premier Medallion - Summit

DONALD J. BALES
President

Bus. Phone (407) 322-4382
Bus. Phone 321-0871

Paint & Body

Stainless Steel

Ted's
Classic Car Restorations

Ted Janowski
(904) 774-5512

2661 San Juan St.
DeLand, FL 32724



PACKARD FARM

Studebaker - Packard
Parts and Accessories
Large Inventory of Rubber Products
We Buy Toy Tractors

97 N. 150 W.
(Road 150 W. & U.S. 40)
Greenfield, IN 46140

BILL McDOWELL
(317) 462-3124

- BUY
- SELL
- TRADE
- ENJOY



STUDEBAKER
CARS - TRUCKS
TOYS - WATCHES

PAUL WHITE
(904) 383-7279

32404 Okaloosa
Sorrento, FL 32776

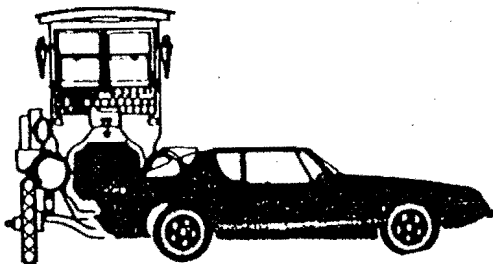

Larry R. Dudley



American
Speedy Printing
Maitland Center

(305) 682-5854

998 Lake Destiny Road
Altamonte Springs, FL 32714

AVANTI LARK HAWK
STUDEBAKER PARTS & REPAIR

R1
R2
R3
R4

SPECIALIZING IN
HARD TO GET PARTS
PERFORMANCE PARTS

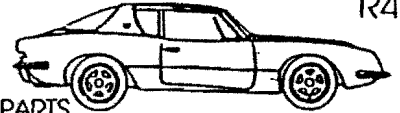

MYER'S STUDEBAKER PARTS
JON B. MYER
3842 BLEDSOE AVE.
LA, CA 90066

AOAI
SDC OEC

(213) 398-1947

Ed Reynolds
(213) 435-0157



1400 Santa Fe Ave. Long Beach, CA 90813

(New Address)

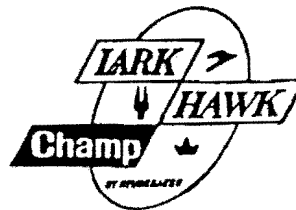

PHIL'S STUDEBAKER
11250 Harrison Rd.
Osceola, IN 46561

(219) 674-0058

N.O.S. and Excellent Used Parts

Special Interest Autos of St. Louis, Inc.

PH. 314-279-1280

MAIL:
P.O. BOX 944
ST. CHARLES, MO 63302

SHIPMENTS:
#5 CHALIN
ST. PETERS, MO 63376

HOURS: MON.-FRI. 8 A.M.-6 P.M.
SAT. 8 A.M.-NOON

Avanti

Avanti II



Studebaker

THE STUDEBAKER DRIVERS CLUB ORLANDO AREA CHAPTER

MEMBERSHIP REGISTRATION FORM DUES \$10.00 PER YEAR (DUE AND RENEWABLE OCT 1)
 (NEW MEMBERS, SEE SCHEDULE BELOW) MAKE CHECKS PAYABLE AND MAIL TO:

ORLANDO AREA CHAPTER - SDC 1025 NODDING PINES WAY CASSELBERRY, FL 32707

NAME _____ BIRTH DATE (MONTH/DAY) _____

SPOUSE _____ BIRTH DATE (MONTH/DAY) _____

ANNIVERSARY DATE (MONTH/DAY) _____

ADDRESS _____

CITY _____ STATE _____ ZIP _____

HOME PHONE _____ WORK PHONE _____

STUDEBAKER OR STUDEBAKER RELATED VEHICLES OWNED

YEAR	NAME	MODEL	BODY STYLE
_____	_____	_____	_____
_____	_____	_____	_____
_____	_____	_____	_____

NEW MEMBER DUES SCHEDULE (PAY AMOUNT INDICATED FOR THE MONTH YOU JOIN)

OCT - \$10.00 NOV - \$10.00 DEC - \$10.00 JAN - \$9.00 FEB - \$8.00 MAR - \$7.00
 APR - \$6.00 MAY - \$5.00 JUN - \$4.00 JUL - \$3.00 AUG - \$2.00 SEP - \$1.00

To join the ORLANDO AREA CHAPTER, you must be a member of the STUDEBAKER DRIVERS CLUB. Dues are \$18.00 per year. Send name, address, phone number to :

S.D.C. NATIONAL OFFICERS 1990-1991

- President - George D. Krem, 1248 Esther Court, Iowa City, Iowa 52240
- Vice President - Denny Lockmon, 9331 Polk Street, Omaha, Nebraska 68127
- Secretary - Linda Costell, 5831 Balfour Road, Sylvania, Ohio 43560
- Treasurer - Colin D. Fort, P.O. Box 1204, La Jolla, California 92038

P.O. Box 28788, Dallas, Texas. 751228-0788. (1-800-527-3452)

The Studebaker Drivers Club, Inc.



Orlando Area Chapter
 1002 Wilda Lake Circle
 Oviedo, Florida 32765

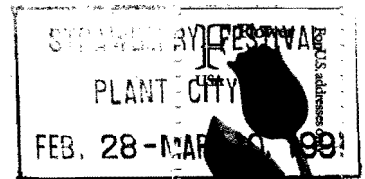

AMBROGIO
 FRANK & ANITA AMBROGIO
 1025 NODDING PINES WAY
 CASSELBERRY, FL 32707

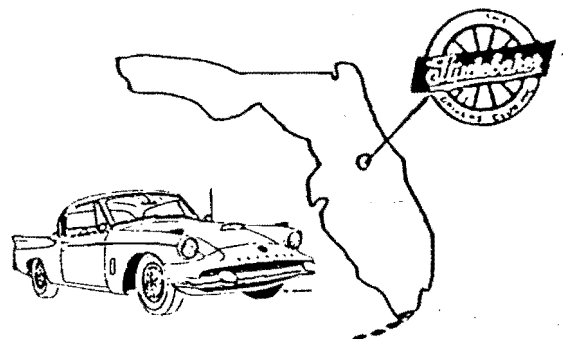
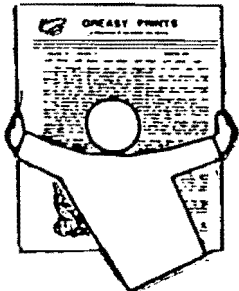



THE STUDEBAKER DRIVERS CLUB

GREASY PRINTS

A BI-MONTHLY PUBLICATION OF THE ORLANDO AREA CHAPTER
ESTABLISHED OCTOBER 15, 1983 CHARTERED JUNE 19, 1984

Volume 8

Number 5

May June 1991

PRESIDENT:	GEORGE MORRILL	1002 WILLA LAKE CIRCLE	OVIEDO	FLORIDA	32765
VICE PRESIDENT:	PAUL WHITE	32404 OKALOOSA TRAIL	SORRENTO	FLORIDA	32776
SECRETARY:	BONNIE GREEMER	3410 S. NASHVILLE	ORLANDO	FLORIDA	32809
TREASURER:	ANITA AMBROGIO	1025 NODDING PINES WAY	CASSELBERRY	FLORIDA	32707
ACTIVITIES:	LARRY GOLUB	102 WILD PLUM	LONGWOOD	FLORIDA	32779
DIRECTORS:	JERRY SHELTON	1660 CASSIDY DRIVE	ST.CLOUD	FLORIDA	34771
	LAMONT CHURCHILL	3410 S. NASHVILLE	ORLANDO	FLORIDA	32809
MEMBERSHIP:	BARBARA GOLUB	102 WILD PLUM	LONGWOOD	FLORIDA	32779
EDITOR:	MARTHA MORRILL	1002 WILLA LAKE CIRCLE	OVIEDO	FLORIDA	32765

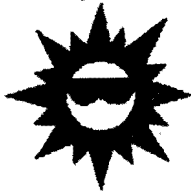

STUDEBAKER



HAVE A GREAT SUMMER

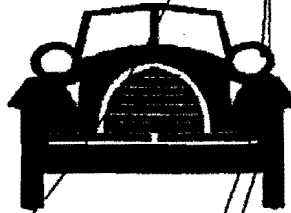

HEADLIGHTS: THE ROAD AHEAD

CALENDAR OF EVENTS

REGULAR MEMBERSHIP MEETING: TIME: 7:00 p.m. WHEN: 2ND Saturday of each month. WHERE: Sanford Motor Co., 3418 S. Orlando Dr. (17-92), Sanford, Fa. (1/2 mile north of Lake Mary Blvd. (Regular meetings will be postponed for June, July, and August. Please contact one of the officers for Studebaker events and information. We will continue meeting for breakfasts.)

CHAPTER BREAKFASTS: TIME: 8:00 A.M. WHEN: Last Sunday of each month. WHERE: Frisch's Big Boy, 605 Lee Road, Orlando, Fa. (just west of I-4, formerly Howard Johnsons), Bring your own Baker, BYOB

APRIL

- 06 RESTORATIONS 91' car show swap. Longwood Village, Hwy 434 Sponsored by Florida Region AACA.
- 13 REGULAR MEMBERSHIP MEETING: TIME: 7:00 p.m. (see address above) ELECTION OF NEW OFFICERS WILL TAKE PLACE AT END OF MEETING.
- 21 ORLANDO AREA CHAPTER SPRING INVITATIONAL ROAD TOUR - POKER RUN. Open to all antique/special interest automobiles. See front page for registration and information.
- 27 15TH ANNUAL HERITAGE CLASSIC sponsored by: Volusia region AACA at Riverfront park, Daytona Beach. For info. Dorothy Brindley, 423 Plumosa Ave. Harbor Oaks, Fl 32127.
- 28 OAC CHAPTER BREAKFAST 8:00 a.m. (see above for details)

MAY

- 11 REGULAR MEMBERSHIP MEETING: TIME 7:00 p.m. (see address above) Cruise to Wendys after meeting. Our last meeting for the summer. We will discuss the plans for the exciting State Meet being held Oct 25, 26th and 27th.
- 26 OAC CHAPTER BREAKFAST 8:00 a.m. (See above for details)

June

- 24-29 SDC INTERNATIONAL MEET Springfield, Missouri (see turning Wheels for more information)
- 30 OAC CHAPTER BREAKFAST 8:00 a.m. (See above for details)

JULY

- 28 OAC CHAPTER BREAKFAST 8:00 a.m. (See above for details)

AUGUST

- 25 OAC CHAPTER BREAKFAST 8:00 a.m. (See above for details)

SEPTEMBER

- 12 Regular Membership Meeting: TIME: 7:00 p.m. Be sure to be there to discuss details of State Meet.
- 29 OAC Chapter Breakfast 8:00 a.m.

Frankly Speaking

OAC POKER RUN

by **FRANK AMBROGIO**

With all the rain we have had in this area since early March, especially on weekends, scheduling any event has been a real gamble. Mother nature dealt the Orlando Area Chapter a royal flush, weather wise, on Sunday April 21 for our Spring Invitational Road Tour/Poker Run.

On what was probably the most beautiful day of the year, Anita and I met the Run organizers, Greg and Kim Case, at Sanford Motors at 9:30 a.m. Although the run did not officially



start until 10:00, there was already a gathering of Studebaker enthusiasts as LeRoy & Helen Gessner, and Dean & Jean Gessner were talking shop with Paul & Marion White, and George & Alexandra (substituting for Martha) Morrill. Arriving shortly thereafter was LaMont Churchill and Bonnie Creemer.

After some last minute instructions, Anita & I departed for our checkpoint station at Sylvan Lake Park just as the contingent of 3 Mustang convertibles was arriving, representing the Antiques Anonymous Club from Mt. Dora.

We drove out to Sylvan Lake Park, set up our position, and waited for the poker playing peregrinators to make the pilgrimage. We were helped out at the Park by one of the rangers who brought over some buoys for us.

At about 10:25, two bulletnoses, one 1958 Commander, three Mustang Convertibles, and an MG roadster piloted

by Richard Johnston and navigated by Paul LeClerc from Fern Park Auto Parts entered the park and lined up to draw their second poker hand card. They had all picked their first card at the registration stop. In about 5 minutes, they were all on their way to the next checkpoint.

This would prove to be our only action for the day as shortly after 11:00, Greg and Kim came by in their 1950 bulletnose, and announced that registrations were closed and no one else had entered. We packed up and followed them on SR 46 to County Road 46A and on to SR 44 to the 2nd checkpoint, Shady Oaks Restaurant. There we caught up with the rest of the players and had a drink and shared some experiences.

Then it was back to the road toward Blue Springs with a little side trip to check out a 50 bulletnose for sale. After giving this tired, but restorable, piece of history the once over, we continued on to Valentine Park where we caught up with George Morrill and his 1964 Daytona. Everyone drew their final two poker hand cards here.

We had a nice covered area all to ourselves and settled in for our picnic lunch. After lunch, Greg announced the winners, none of which was me. The winners were the two of the Mustang owners (who probably have real names), Dean Gessner, George Morrill and our Roving Reporter, Paul White (aka Light Fingers

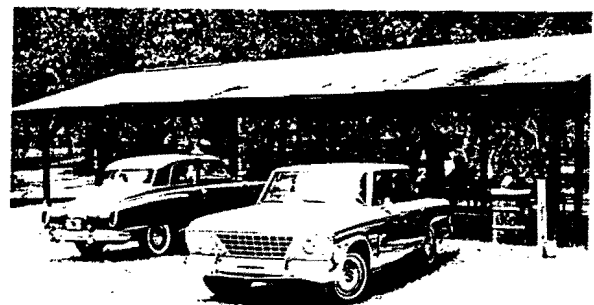

SEARCHLIGHTS:

CLASSIFIED ADS:

Ads are free to members and run for 2 issues.
Please include the city and area code if a phone number is given.
Deadline for ads is the 20th of the month preceding publication

Parts For Sale

Lark dome light-\$3.00
Power Steering Pump -\$25.00
C-K Rocker panel -\$40.00
63 Grille - \$20.00
59-60 Lark Vent Windows-\$10.00
Speedster wire covers w/caps -
\$200.00
63 Hawk radiator \$25.00
55 dSedan front and rear vent
windows \$10.00
62-63 Headlite rims \$10.00 set
Driveshafts - choice \$10.00
62 and 63 Convertible top latches
\$20-35
Used V-8 carbs \$15.00
62-3-4 Lark-Cruiser spindles \$15.00
Clutch disc and pressure plate 10
1/2 inch, \$35.00
V-8 Overdrive transmission \$175.00
1963 Trunk lid, \$50
1953 Land Cruiser window vent
shades \$20 set
1957 Hawk Grille \$35.00

Call PAUL WHITE 904-383-7279

AVANTI PARTS FOR SALE

1963-64 Left front fender \$200
Stainless Exhaust \$200
Water Pump \$65.00
Water Pump Pulley \$55.00
Roof Chrome Emblems \$20.00 for pair

Call GEORGE MORRILL 407-365-4935

TECH TIP

With the advent of warmer weather most of us have taken the Studebaker out on it's '91 maiden voyage. Along with the warmer weather comes club activities which include showing off that Studebaker in parades, shows and possibly some cruising. All of us want that pride and joy to look it's best and spend a great deal of time cleaning and polishing.

Stopping short of a fresh paint job, a lot can be done to enhance it's present paint, providing there is enough paint to work with. Each time a rubbing compound or wax with cleaner is used, a minute portion of paint leaves the car and becomes a part of the polishing cloth. This is great at shows because you have a polishing cloth that matches your car...perfectly.

Rubbing compounds come in various grit, some that will eliminate scratches while removing quite a bit of paint, to those of finer compounds that are meant to remove oxidation of the paint. If the paint is getting thin, rubbing compounds should be avoided altogether.

Most any paint can be brought back to life. Blue Coral Wax in the two step application is quite hard to find, probably because of the labor in application, but will produce the best results of any on the market today. The cleaner portion of the kit allows you to clean an area of oxidation or dead paint until the desired shine appears. The cleaner is applied and worked while wet, generally working in a two square foot area. Some areas such as hood and trunk will take more than one application. After the desired results are obtained the second portion of the kit is applied which merely seals in the shine.

After the initial treatment, yearly upkeep is much easier. The sealer alone may be used for a period of time, however wax buildup will occur over a period of time and a haze will appear. This will signal that its time to break out the cleaner again, and start over.

Tech Tip taken from Michiana Chapter
HOME OF CHAMPIONS May 1991

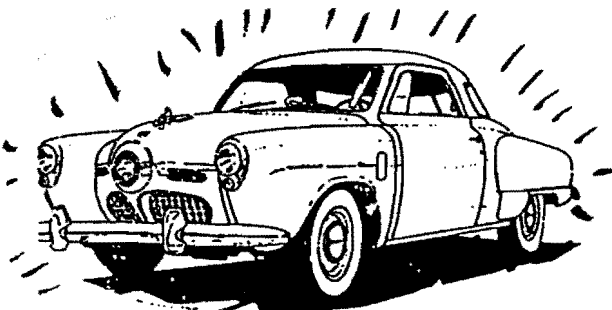

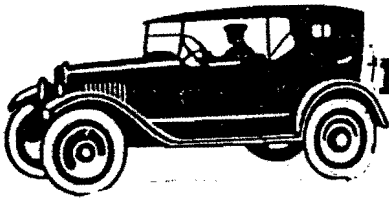

PRESIDENT'S CORNER

Summer is fast approaching, we have chosen to suspend meetings for the hot months of June, July, and August. If anyone has any information that needs to be distributed to the membership during those months please notify me or one of the club officers, and we will see that the information is distributed.

The meeting of May 11 will be important, as we will be discussing and choosing some of the materials that we will be selling or distributing at the State Meet in October.

The Poker Run held in April was quite successful for our first attempt. Those attending hoped that this could be at least an annual event. There were seven Studebakers from our club, three Mustang convertibles from Antiques Anonymous, and one orphan MiGi. Everyone enjoyed the scenery and low paced traffic. There were no worries about getting to a check point at a certain time, just making sure you found all of them and getting their cards.

The main topics of the last two meetings have been the State Meet and the election of officers for the next year. Officers were elected as follows:

President; George Morrill, Vice President; Paul White, Secretary; Bonnie Creemer, Treasurer; Anita Ambrogio, Activities; Greg Case, Lamont Churchill, Larry Golub, Membership; Frank Ambrogio, Greasy Prints Editor: Martha

As I mentioned above the May and September Meetings will be very important for making this years State Meet a success. Hope to see everyone attending.

Birthday announcements



HAPPY BIRTHDAY

HENRY	KENDRICK	0524
LETA M.	LONG	0516
BILL	MCDOWELL-PACKARD FARM	0506
SCOTT	PILOIAN	0530

HAPPY ANNIVERSARY

RANDY & MARTHA SNYDER	0501
-----------------------	------



HAPPY BIRTHDAY

ANITA	AMBROGIO	0613
JACKIE	BERMAN	0630
MARY	CADE	0629
JAMES W.	CADE	0627
KATHRYN C.	CASE	0608
BILL	HAHN	0603
TED	JANOWSKI	0627
BILL	PELICK	0618

HAPPY ANNIVERSARY

DR. ROBERT & MARY CADE	0601
GREG & KIM CASE	0617
JEFF & LOU ELLIOTT	0617
DEAN & JEAN GESSNER	0603
KEN & EDNA RUTH HARRELL	0630

Anniversary announcements



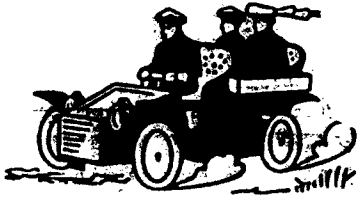

Roving Reporter By Paul White

Not rovin' but I've been thinking again! Do any of you remember the days when so called Car shows were just a lot of fun and swap meets were exciting and interesting and a darn good source of finding a few parts you could use and maybe even a few you thought you might use someday?? What happened? I guess it just got to be too much of a hassle for must folks to sort out, load up, and haul to the meet, rent a space, (now the price of two hotel rooms at Motel 6) unload the goodies, put up with the chislers, load it up, haul it home, and put it away again. No wonder the little guy has just about become extinct at swap meets and has given way to the pro's with their Buffalo tools, fuzzy dice, and beer cans.

At our State Meet '91 in Gainesville in October we hope to breathe a little new life into the swap meet remains with the very newest Space-Age Hi Tech approach to making those "no longer essential to you" parts and accessories available. *The Orlando Chapter exclusive '91 extravaganza - Trunk Swap '91.* Don't get too excited there Bakerbuddies as we still have several months to go. However it is not too early to rummage around your Baker barn, under the bed, out back, etc. and start thinking (it doesn't hurt) about the 6 or 8 goodies you can take to the State Meet right in the trunk of your car. The "plan" is set aside one hour (to be anounced) during "show day" when everyone opens their trunks to display the gorgeous wares they have brought to sell or swap.

Of course, for the true-blue vendor that wants to rent a "regular" space (other than his or her Baker trunk) we will be glad to accomodate!! We will GIVE you a space!!!

See you in Gainesville in October. Don't miss it! It's going to be a humdinger---or should that be a Bakerdinger?

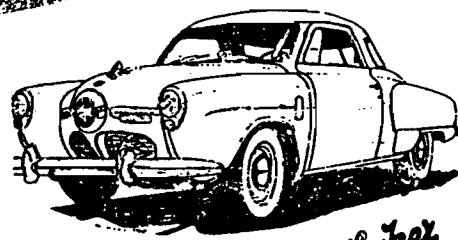

Studebaker

SANFORD MOTOR CO., INC.

3418 S. Orlando Dr.
SANFORD, FLORIDA 32773



Cherokee - Comanche - Wrangler - Wagoneer - Premier Medallion - Summit

DONALD J. BALES
President

Bus. Phone (407) 322-4382
Bus. Phone 321-0871

Paint & Body

Stainless Steel

Ted's
Classic Car Restorations

Ted Janowski
(904) 774-5512

2661 San Juan St.
DeLand, FL 32724



PACKARD FARM

Studebaker - Packard
Parts and Accessories
Large Inventory of Rubber Products
We Buy Toy Tractors

97 N. 150 W.
(Road 150 W. & U.S. 40)
Greenfield, IN 46140

BILL McDOWELL
(317) 462-3124

- BUY
- SELL
- TRADE
- ENJOY



STUDEBAKER
CARS - TRUCKS
TOYS - WATCHES

PAUL WHITE
(904) 383-7279

32404 Okaloosa
Sorrento, FL 32776

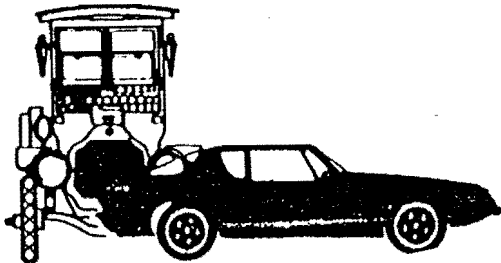

Larry R. Dudley

American
Speedy Printing
Maitland Center



(305) 682-5854

998 Lake Destiny Road
Altamonte Springs, FL 32714

AVANTI LARK HAWK
STUDEBAKER PARTS & REPAIR

R1
R2
R3
R4

SPECIALIZING IN
HARD TO GET PARTS
PERFORMANCE PARTS

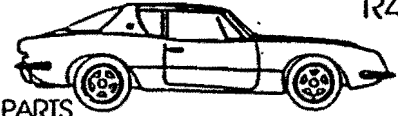

MYER'S STUDEBAKER PARTS

JON B. MYER
3842 BLEDSOE AVE.
LA, CA 90066

AOAI
SDC OEC
(213) 398-1947

Ed Reynolds
(213) 435-0157



1400 Santa Fe Ave. Long Beach, CA 90813

(New Address)

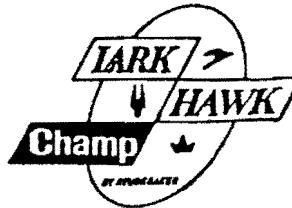

PHIL'S STUDEBAKER
11250 Harrison Rd.
Osceola, IN 46561

(219) 674-0058

N.O.S. and Excellent Used Parts

Special Interest Autos of St. Louis, Inc.

PH. 314-279-1280

MAIL: P.O. Box 944
ST. CHARLES, MO 63302

SHIPMENTS:
#5 CHALIN
ST. PETERS, MO 63376

HOURS: MON.-FRI. 8 A.M.-6 P.M.
SAT. 8 A.M.-NOON

Avanti

Avanti



Studebaker

THE STUDEBAKER DRIVERS CLUB ORLANDO AREA CHAPTER
MEMBERSHIP REGISTRATION FORM DUES \$10.00 PER YEAR (DUE AND RENEWABLE OCT 1)
(NEW MEMBERS, SEE SCHEDULE BELOW) **MAKE CHECKS PAYABLE AND MAIL TO:**
ORLANDO AREA CHAPTER - SDC 1025 NODDING PINES WAY CASSELBERRY, FL 32707

NAME _____ BIRTH DATE (MONTH/DAY) _____
 SPOUSE _____ BIRTH DATE (MONTH/DAY) _____
 ANNIVERSARY DATE (MONTH/DAY) _____

ADDRESS _____
 CITY _____ STATE _____ ZIP _____
 HOME PHONE _____ WORK PHONE _____

STUDEBAKER OR STUDEBAKER RELATED VEHICLES OWNED

YEAR	NAME	MODEL	BODY STYLE
_____	_____	_____	_____
_____	_____	_____	_____
_____	_____	_____	_____

NEW MEMBER DUES SCHEDULE (PAY AMOUNT INDICATED FOR THE MONTH YOU JOIN)

OCT - \$10.00 NOV - \$10.00 DEC - \$10.00 JAN - \$ 9.00 FEB - \$ 8.00 MAR - \$ 7.00
 APR - \$ 6.00 MAY - \$ 5.00 JUN - \$ 4.00 JUL - \$ 3.00 AUG - \$ 2.00 SEP - \$ 1.00

To join the ORLANDO AREA CHAPTER, you must be a member of the STUDEBAKER DRIVERS CLUB. Dues are \$18.00 per year. Send name, address, phone number to :

S.D.C. NATIONAL OFFICERS 1990-1991
 President - George D. Krem, 1248 Esther Court, Iowa City, Iowa 52240
 Vice President - Denny Lockmon, 9331 Polk Street, Omaha, Nebraska 68127
 Secretary - Linda Costell, 5831 Balfour Road, Sylvania, Ohio 43560
 Treasurer - Colin D. Fort, P.O. Box 1204, La Jolla, California 92038

P.O. Box 28788, Dallas, Texas. 751228-0788. (1-800-527-3452)

The Studebaker Drivers Club, Inc.



Orlando Area Chapter
 1002 Willa Lake Circle
 Oviedo, Florida 32765

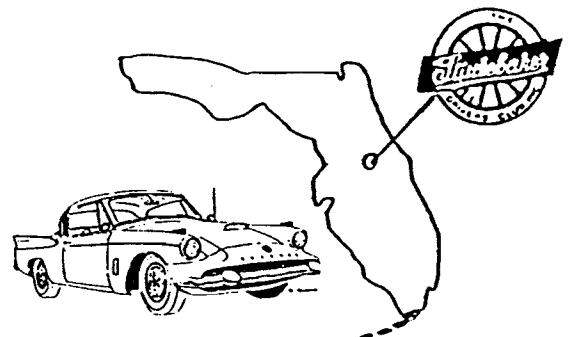
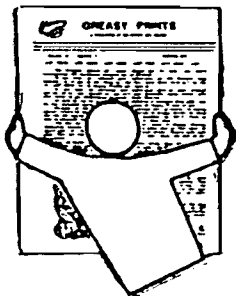

THE STUDEBAKER DRIVERS CLUB

GREASY PRINTS

A BI-MONTHLY PUBLICATION OF THE ORLANDO AREA CHAPTER
ESTABLISHED OCTOBER 15, 1983 CHARTERED JUNE 19, 1984

Volume 8 Number 6 September-October

PRESIDENT:	GEORGE MORRILL	1002 WILLA LAKE CIRCLE	OVIEDO	FLORIDA	32765
VICE PRESIDENT:	PAUL WHITE	32404 OKALOOSA TRAIL	SORRENTO	FLORIDA	32776
SECRETARY	BONNIE CREEMER	4070 KINGSPORT DRIVE	ORLANDO	FLORIDA	32809
TREASURER:	ANITA AMBROGIO	1025 NODDING PINES WAY	CASSELBERRY	FLORIDA	32707
ACTIVITIES	LARRY GOLUB	102 WILD PLUMB	LONGWOOD	FLORIDA	32779
DIRECTORS:	JERRY SHELTON	1660 CASSIDY WAY	ST. CLOUD	FLORIDA	34771
	LAMONT CHURCHILL	4070 KINGSPORT DRIVE	ORLANDO	FLORIDA	32809
MEMBERSHIP:	FRANK AMBROGIO	1025 NODDING PINES WAY	CASSELBERRY	FLORIDA	32707
EDITOR:	MARTHA MORRILL	1002 WILLA LAKE CIRCLE	OVIEDO	FLORIDA	32765

14th Annual Studebaker Florida State Meet



Gainesville

**October
25th & 26th**

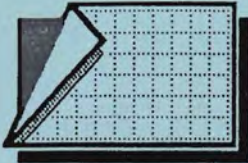

HEADLIGHTS: *THE ROAD AHEAD*

CALENDAR OF EVENTS

GREASY PRINTS

REGULAR MEMBERSHIP MEETINGS: 7:00 PM, 2nd Saturday of each month at Sanford Motor Co. 3418 S.Orlando Dr. (17-92) Sanford, Florida (1/2 mile north of Lake Mary Blvd).

CHAPTER BREAKFASTS: 8:00 AM, last sunday of each month at Frisch's Big Boy 605 Lee Road Orlando, Florida (just west of I-4, formerly Howard Johnsons), Bring Your Old Baker (BYOB)

SEPTEMBER 1991

29 OAC Chapter Breakfast at 8:00 am. Frisch's Big Boy 605 Lee Road Orlando, Florida (just west of I-4)

OCTOBER 1991

12 REGULAR MEMBERSHIP MEETING 7:00 pm at Sanford Motors Inc. (see address above). Cruise to Wendys after the meeting.

25-27 FLORIDA STATE MEET in Gainesville at Howard Johnson..

27 Breakfast in Gainesville.. See you at the State meet.

NOVEMBER 1991

02 CELERY CITY CRUISERS Eighth Annual Car show, Downtown Sanford. For more information call Herb Partridge at 407-322-3687.

09 REGULAR MEMBERSHIP MEETING 7:00 pm at Sanford Motors Inc. (see address above). Cruise to Wendys after the meeting.

24 OAC Chapter Breakfast at 8:00 am. Frisch's Big Boy 605 Lee Road Orlando, Florida (just west of I-4)

DECEMBER 1991

12 7TH ANNUAL CAR SHOW & FLEA MARKET at Renningers Antique Center, Florida Twin Markets in Mount Dora on Rt. 441. Call Sid Trask 904-357-1614.

14 REGULAR MEMBERSHIP MEETING 7:00 pm at Sanford Motors Inc. (see address above). Cruise to Wendys after the meeting.

29 OAC Chapter Breakfast at 8:00 am. Frisch's Big Boy 605 Lee Road Orlando, Florida (just west of I-4)

HAPPY BIRTHDAY

SABRINA M.	CADE	1125
ROBERT A.	CADE	1119
GREGORY P.	CASE	1116
THELMA	CHAPMAN	1104
LEROY	GESSNER	1128
KEN	HARRELL	1107
LEROY M.	LONG	1116
MARTHA E.	MORRILL	1125
ALEXANDRA	MORRILL	1120
MICHELLE D	MYER (MYERS STUDEBAKER)	
CAROLYN	SWANSON	1116
DOROTHY	THOMAS	1126

HAPPY BIRTHDAY

JOANN	GORMICAN	1015
MARY ANN	HACKETT	1029
JUDY	KENDRICK	1015

HAPPY ANNIVERSARY

FRANK & ANITA	AMBROGIO	1016
STU & THELMA	CHAPMAN	1004
ROBERT & LORRAINE	COOLIDGE	1015
JERRY & TERRY	GIMZEK	1014
JACK & SANDY	MORGAN	1028
DWIGHT & CAROLYN	SWANSON	1014

HAPPY ANNIVERSARY

TED & BEVERLY	JANOWSKI	1126
DAVID & ROBERTA	JOHNSTON	1103
RICHARD & MARJORIE	LATCHAW	1127
FRED & SUE	LAYMAN JR.	1130

Presidents Corner

The last week of June brought 14 days of Studebaker Heaven for this leader. I had the opportunity to attend the International SDC Meet in Springfield Mo. Not only attend the meet but to have the pleasure of driving to and from the meet in one of Dr. Cades Studebakers. We traveled in a caravan of eight studes plus a 1928 Erskin which was toled by trailer. Of course there were the several mechanical failures, but there was ample help and spare parts available to handle the problems. It took 3 days traveling to and from the Meet.

While at the Meet, the Swap Meet (chigger ranch), was located right behind the motel where we were registered which made it only a short distance to carry that treasured find (a front door, door handles,...), more items than I had planned to purchase.

I had the pleasure of meeting new people and renewing some friendships from past Meets. Several members from our chapter were there, a pleasant surprise when you are that far from home.

The Ozark Chapter is to be commended for this wonderful Meet. All the events were well planned and staffed, registration went smoothly the hospitality room was always staffed with friendly faces and plenty of goodies. In all a very enjoyable week in the Ozarks.

Back to the driving, though it was quite hot at times, the pleasure of driving these pieces of history and satisfaction received as people along the way recognized the 9 cars as we traveled down the road was well worth enduring the heat. The number of cars returning increased by one as Dr Cade purchased a 54 Conestoga Wagon at the Meet. I hope to have our Daytona ready to drive to Nashville next year.

MEMBERSHIP DUES RENEWAL TIME:

by Frank Ambrogio MD

(Membership Director)

October marks the end our 8th year as a Club and with that comes renewal time. Dues are still \$10.00, the same as they were when the Club was formed in October, 1983. I hope each of you will renew promptly and make my job a little easier.

Please fill out the membership form and mail it along with your \$10.00 to me at the Club address, 1025 Nodding Pines Way, Casselberry, Florida 32707

MINUTES OF THE REGULAR STUDEBAKER MEETING

September 14, 1991

The first meeting of the year was attended by many members. The meeting place was switched to George Morrill's home so there would be air conditioning to offset the warm evening and every chair was filled. Those who attended were Frank and Anita Ambrogio, Casselberry; Jeff and Lou Elliott, Sorrento; John and Joann Gormican, Apopka; Dean and Jean Gessner, Yalaha; Greg and Kim Case, Orlando; Keith Creemer and Marysue Haugan, Orlando; Leroy and Helen Gessner, Oxford; Larry and Barbara Golub, Longwood; Oscar Koberg and guest, Deltona; Leroy and Leta Long, Casselberry; George and Martha Morrill, Oviedo; Paul and Barbara Parker, Inglis; Jerry and Cindi Shelton, St. Cloud. The entertainment for the evening was Stephen and Wende Cade, their two sons and Russell Lane who drove

Search Lights:

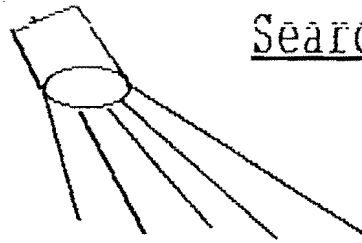

from Gainesville in a Cadillac Convertible complete with a set of steerhorns attached to the front hood and Texas plates to boot. Yeehah! Also driven were a 64 Challenger, 50 and 51 Studebakers.

The group worked on plans for the 1991 State Meet. Groups to head up different tasks were formed and a complete list will be ready for the next meeting and available for sign-up. Volunteers needed! 20 people registered for the State Meet so far. It was decided to include a copy of the registration in this month's newsletter.

50-50 drawing was held. George Morrill was the winner. \$7.00 for chapter and \$7.00.

Meeting adjourned followed by refreshments.

FOR SALE

1957 Golden Hawk- Automatic, P/S, P/B, P/W, P/SEAT, \$1,500.00 in rebuilt engine, recent transmission rebuild, needs restoration to be show car. Body very good, interior fair. Have supercharger (not on car). \$4,500.00. Also have complete add-on air, will sell with car or separate. Car is in St. Cloud, FL.

Phone (407) 957-9095.

To John and JoAnn Gormican and their family, The Orlando Area Chapter sends its heartfelt prayers and thoughts for the loss of their son Anthony.



**STUDEBAKER DRIVERS CLUB
14TH ANNUAL FLORIDA STATE MEET
HOSTED BY THE ORLANDO AREA CHAPTER
OCTOBER 25-26, 1991 in GAINESVILLE, FLORIDA**

HOST MOTEL: HOWARD JOHNSON 7400 N.W. 8TH AVENUE (S.R.26) GAINESVILLE

NAME _____

ADDRESS _____

CITY _____ ST _____ ZIP _____ PHONE (____) _____

REGISTRATION INFORMATION

GENERAL REGISTRATION (INCLUDES MEET HANDBOOK AND DASH PLAQUE) \$ 3.00
 CAR SHOW, 1ST VEHICLE (BEFORE OCT 15, 1991 - \$3.00, AFTER OCT 15 \$5.00) \$ _____
 2ND VEHICLE ENTERED _____ 1 @ \$ 3.00 \$ _____
 ADDITIONAL VEHICLES *CARS _____ @ N/C \$ FREE
 TROPHY SPONSOR * _____ @ \$20.00 \$ _____
 *BANQUET (Deadline Oct 22 - INCLUDES CAR DRAWING) (children under 12)
 10 OZ. STEAK *ADULTS _____ @ \$12.00 + *CHILDREN _____ @ \$ 7.00 \$ _____
 CHICKEN BREAST *ADULTS _____ @ \$12.00 + *CHILDREN _____ @ \$ 7.00 \$ _____
 BBQ BUFFET LUNCH IN HOSPITALITY ROOM, SATURDAY * PERSONS _____ \$ FREE
 TEA PARTY (FOR LADIES) SATURDAY, FREE TRANSPORTATION * PERSONS _____ \$ FREE
TOTAL (MAKE CHECKS PAYABLE TO ORLANDO AREA CHAPTER - SDC) \$ _____

*** TRUNK SWAP MEET (NEW THIS YEAR): LOAD YOUR TRUNK WITH YOUR *****
 EXTRA PARTS. WE WILL HAVE A SWAP MEET AT A DESIGNATED TIME DURING THE SHOW ON SATURDAY.

LIST ALL VEHICLES TO BE ENTERED IN THE SHOW

YEAR	MODEL/STYLE (President 2 door etc.)	CLASS (see below)
_____	_____	_____
_____	_____	_____
_____	_____	_____

CLASSES:

- | | | |
|---|---------------------------|-----------------------------------|
| 1 PREWAR | 2 1947 - 1952 (ALL) | 3 1953 - 1955 COUPES AND HARDTOPS |
| 4 1953 - 1958 SEDANS, WAGONS | 5 1956 - 1961 HAWKS/HDTPS | 6 1959-1963 LARKS |
| 7 1962 - 1964 GT HAWKS | 8 1964-1966 STUDEBAKERS | 9 1963 - 1964 STUDEBAKER AVANTI |
| 10 COMMERCIAL | 11 MODIFIED | 12 1965 - 1991 AVANTI II/AVANTI |
| 13 DISPLAY ONLY, NOT FOR JUDGING (no charge for this class) (NOTE: CLASS 4 AND 5 INCLUDES PACKARDS) | | |

I DO HEREBY RELEASE AND HOLD HARMLESS, ORLANDO AREA CHAPTER - SDC FROM ANY SUITS, ACTIONS, DAMAGES OR CLAIMS WHICH MAY ARISE FROM ANY LOSS OR DAMAGES TO ME OR TO MY PERSONAL PROPERTY.

SIGNED _____ DATE _____

(REGISTRATION WILL NOT BE ACCEPTED WITHOUT SIGNATURE)

FOR MORE INFORMATION, CALL WENDE CADE 904-462-1081

MAIL COMPLETED REGISTRATION FORM TO:

ANITA AMBROGIO 1025 NODDING PINES WAY CASSELBERRY, FL 32707

* ALL ADULT BANQUET TICKET HOLDERS WHO ATTEND THE BANQUET ARE AUTOMATICALLY ENTERED IN THE DRAWING FOR THE 1963 STUDEBAKER 4 DOOR 6 CYL V/DISK BRAKES "MISSISSIPPI MUD LARK" DOOR PRIZE CAR. (YOU MUST BE PRESENT TO WIN).

--- SUPPORT OUR SPONSORS ---

SANFORD MOTOR CO., INC.

3418 S. Orlando Dr.
SANFORD, FLORIDA 32773

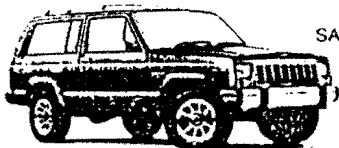

Cherokee Comanche Wrangler Wagoneer Premier Medallion Summit

DONALD J. BALES
President

Bus. Phone (407) 322-4382
Bus. Phone 321-0871

Paint & Body

Stainless Steel

Ted's
Classic Car Restorations

Ted Janowski
(904) 774-5512

2661 San Juan St.
DeLand, FL 32724

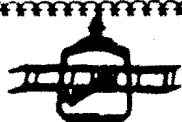

PACKARD FARM

Studebaker - Packard
Parts and Accessories
Large Inventory of Rubber Products
We Buy Toy Tractors

97 N. 150 W.
(Road 150 W. & U.S. 40)
Greenfield, IN 46140

BILL McDOWELL
(317) 462-3124

- BUY
- SELL
- TRADE
- ENJOY



STUDEBAKER
CARS - TRUCKS
TOYS - WATCHES

PAUL WHITE
(904) 383-7279

32404 Okaloosa
Sorrento, FL 32776

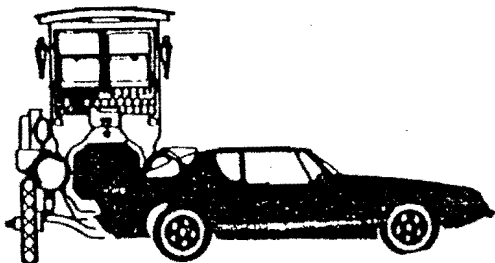

Larry R. Dudley

American
Speedy Printing
Maitland Center



(305) 682-5854

998 Lake Destiny Road
Altamonte Springs, FL 32714

AVANTI LARK HAWK
STUDEBAKER PARTS & REPAIR

R1
R2
R3
R4

SPECIALIZING IN
HARD TO GET PARTS
PERFORMANCE PARTS

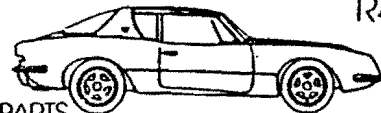

MYER'S STUDEBAKER PARTS

JON B. MYER
3842 BLEDSOE AVE.
LA, CA 90066

AOAI
SDC OEC
(213) 398-1947

Ed Reynolds
(213) 435-0157



1400 Santa Fe Ave. Long Beach, CA 90813

(New Address)

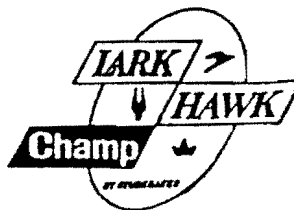

PHIL'S STUDEBAKER
11250 Harrison Rd.
Osceola, IN 46561

(219) 674-0058

N.O.S. and Excellent Used Parts

Special Interest Autos of St. Louis, Inc.

PH. 314-279-1280

MAIL:
P.O. Box 944
ST. CHARLES, MO 63302

SHIPMENTS:
#S CHALIN
ST. PETERS, MO 63376

HOURS: MON.-FRI. 8 A.M.-6 P.M.
SAT. 8 A.M.-NOON

Avanti

Avanti II



Studebaker

THE STUDEBAKER DRIVERS CLUB

ORLANDO AREA CHAPTER

MEMBERSHIP REGISTRATION FORM

DUES \$10.00 PER YEAR (DUE AND RENEWABLE OCT 1)

(NEW MEMBERS, SEE SCHEDULE BELOW)

MAKE CHECKS PAYABLE TO AND MAIL TO:

ORLANDO AREA CHAPTER - SDC

1025 NODDING PINES WAY

CASSELBERRY, FLORIDA 32707

NAME _____ BIRTH DATE (MONTH/DAY) _____

SPOUSE _____ BIRTH DATE (MONTH/DAY) _____

ANNIVERSARY DATE (MONTH/DAY) _____

ADDRESS _____

CITY _____ STATE _____ ZIP _____

HOME PHONE _____ WORK PHONE _____

STUDEBAKER OR STUDEBAKER RELATED VEHICLES OWNED

YEAR	NAME	MODEL	BODY STYLE
_____	_____	_____	_____
_____	_____	_____	_____
_____	_____	_____	_____
_____	_____	_____	_____

NEW MEMBER DUES SCHEDULE (PAY AMOUNT INDICATED FOR THE MONTH YOU JOIN)

OCT - \$10.00 NOV - \$10.00 DEC - \$10.00 JAN - \$9.00 FEB - \$8.00
MAR - \$7.00 APR - \$6.00 MAY - \$5.00 JUN - \$4.00 JUL - \$3.00
AUG - \$2.00 (or \$10.00 for 14 months) SEP - \$1.00 (or \$10.00 for 13 months)

DUES PAID TO OCT 1, 1992

=====

TO JOIN THE ORLANDO AREA CHAPTER, YOU MUST BE A MEMBER OF THE STUDEBAKER DRIVERS CLUB, - DUES ARE \$20.00 PER YEAR.

SEND YOUR NAME, ADDRESS, PHONE NUMBER TO:

THE STUDEBAKER DRIVERS CLUB, INC.

C.I.S., P. O. BOX 28788

DALLAS, TEXAS 75228-0788

IF YOU HAVE ANY QUESTIONS, CALL TOLL FREE 1-800-527-3452
A COMPLETE MEMBERSHIP ROSTER IS AVAILABLE FOR \$6.00 PLUS POSTAGE

THE STUDEBAKER DRIVERS CLUB ORLANDO AREA CHAPTER

MEMBERSHIP REGISTRATION FORM DUES \$10.00 PER YEAR (DUE AND RENEWABLE OCT 1)

(NEW MEMBERS, SEE SCHEDULE BELOW) MAKE CHECKS PAYABLE AND MAIL TO:

ORLANDO AREA CHAPTER - SDC 1025 NODDING PINES WAY CASSELBERRY, FL 32707

NAME _____ BIRTH DATE (MONTH/DAY) _____

SPOUSE _____ BIRTH DATE (MONTH/DAY) _____

ANNIVERSARY DATE (MONTH/DAY) _____

ADDRESS _____

CITY _____ STATE _____ ZIP _____

HOME PHONE _____ WORK PHONE _____

STUDEBAKER OR STUDEBAKER RELATED VEHICLES OWNED

YEAR	NAME	MODEL	BODY STYLE
_____	_____	_____	_____
_____	_____	_____	_____
_____	_____	_____	_____

NEW MEMBER DUES SCHEDULE (PAY AMOUNT INDICATED FOR THE MONTH YOU JOIN)

OCT - \$10.00 NOV - \$10.00 DEC - \$10.00 JAN - \$9.00 FEB - \$8.00 MAR - \$7.00
 APR - \$6.00 MAY - \$5.00 JUN - \$4.00 JUL - \$3.00 AUG - \$2.00 SEP - \$1.00

To join the ORLANDO AREA CHAPTER, you must be a member of the STUDEBAKER DRIVERS CLUB. Dues are \$18.00 per year. Send name, address, phone number to:

S.D.C. NATIONAL OFFICERS 1990-1991

- President - Terry Judd, P. O. Box 736, Grand Haven, Michigan 49417
- Vice President - Denny Lockmon, 9331 Polk Street, Omaha, Nebraska 68127
- Secretary - Linda Costell, 5831 Balfour Road, Gylvania, Ohio 43560
- Treasurer - Colin D. Fort, P.O. Box 1204, La Jolla, California 92038

P.O. Box 28788, Dallas, Texas. 75128-0788. (1-800-527-3452)

The Studebaker Drivers Club, Inc.



Orlando Area Chapter
 1002 Willa Lake Circle
 Oviedo, Florida 32765



AMBROGIO
 FRANK & ANITA AMBROGIO
 1025 NODDING PINES WAY
 CASSELBERRY, FL 32707

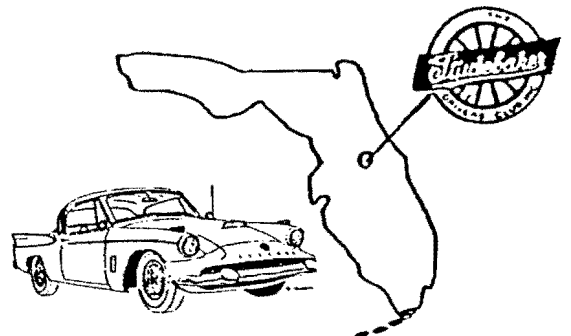
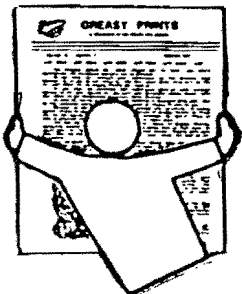

THE STUDEBAKER DRIVERS CLUB

GREASY PRINTS

A BI-MONTHLY PUBLICATION OF THE ORLANDO AREA CHAPTER
ESTABLISHED OCTOBER 15, 1983 CHARTERED JUNE 19, 1984

Volume 8 Number 7

NOVEMBER 1991

PRESIDENT:	GEORGE MORRILL	1002 WILLA LAKE CIRCLE	OVIEDO	FLORIDA	32765
VICE PRESIDENT:	PAUL WHITE	32404 OKALOOSA TRAIL	SORRENTO	FLORIDA	32776
SECRETARY	BONNIE GREEMER	4070 KINGSPORT DRIVE	ORLANDO	FLORIDA	32809
TREASURER:	ANITA AMBROGIO	1025 NODDING PINES WAY	CASSELBERRY	FLORIDA	32707
ACRIVITIES	LARRY GOLUB	102 WILD PLUMB	LONGWOOD	FLORIDA	32779
DIRECTORS:	JERRY SHELTON	1660 CASSIDY WAY	ST. CLOUD	FLORIDA	34771
	LAMONT CHURCHILL	4070 KINGSPORT DRIVE	ORLANDO	FLORIDA	32809
MEMBERSHIP:	FRANK AMBROGIO	1025 NODDING PINES WAY	CASSELBERRY	FLORIDA	32707
EDITOR:	MARTHA MORRILL	1002 WILLA LAKE CIRCLE	OVIEDO	FLORIDA	32765

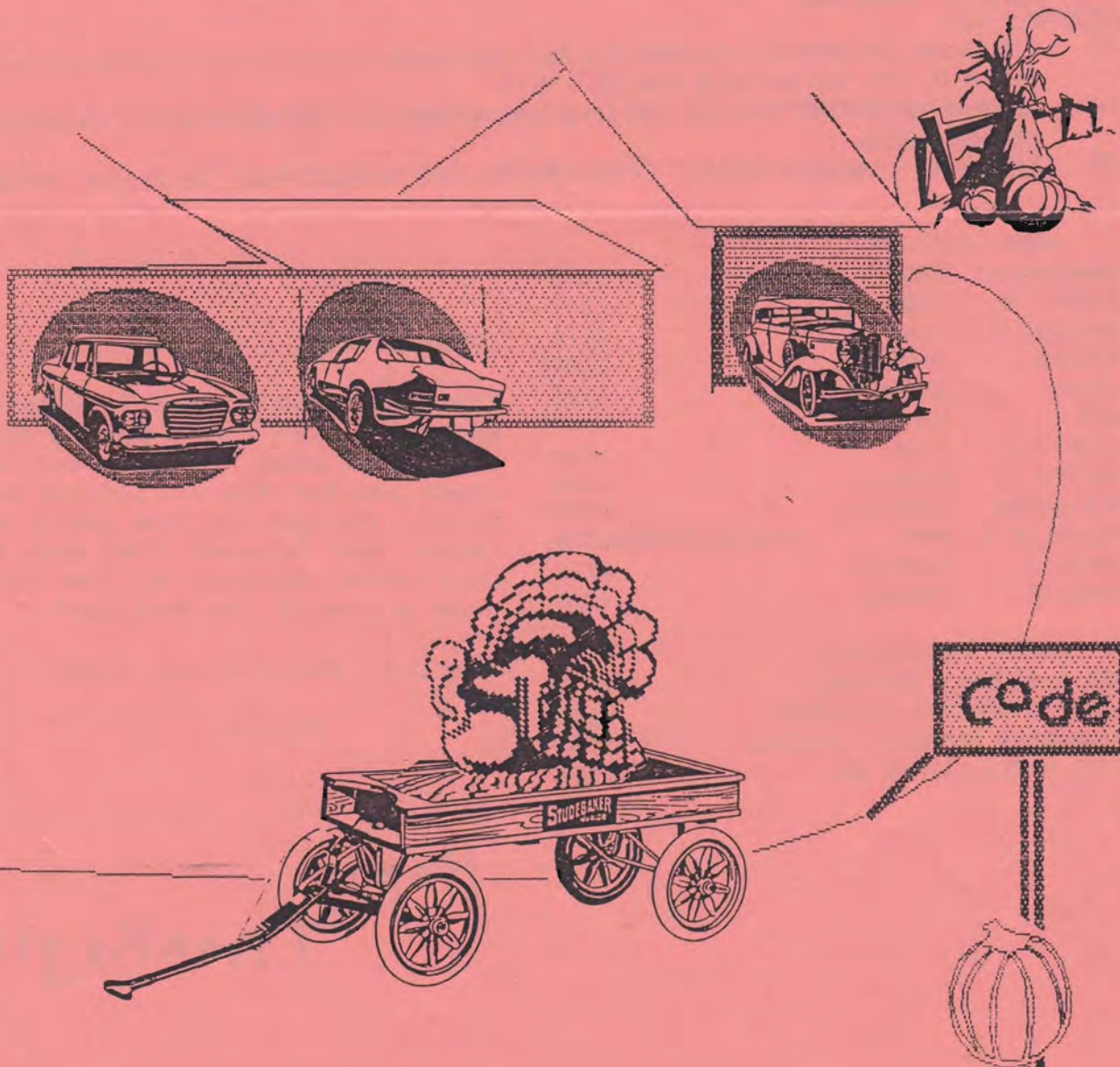

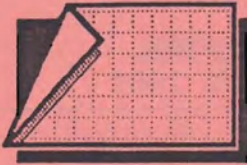

HEADLIGHTS: THE ROAD AHEAD

GREASY PRINTS

CALENDAR OF EVENTS

REGULAR MEMBERSHIP MEETINGS: 7:00 PM, 2nd Saturday of each month at Sanford Motor Co. 3418 S.Orlando Dr. (17-92) Sanford, Florida (1/2 mile north of Lake Mary Blvd).

CHAPTER BREAKFASTS: 8:00 AM, last sunday of each month at Frisch's Big Boy 605 Lee Road Orlando, Florida (just west of I-4, formerly Howard Johnsons), Bring Your Old Baker (BYOB)

NOVEMBER 1991

- 02 CELERY CITY CRUISERS Eighth Annual Car show, Downtown Sanford. For more information call Herb Partridge at 407-322-3687.
- 09 REGULAR MEMBERSHIP MEETING 7:00 pm at Sanford Motors Inc. (see address above). Cruise to Wendys after the meeting.
- 24 OAC Chapter Breakfast at 8:00 am. Frisch's Big Boy 605 Lee Road Orlando, Florida (just west of I-4)
NOTE : DECEMBER 8, SUNDAY. CHRISTMAS PARTY. See inside for further details...

DECEMBER 1991

- 12 7TH ANNUAL CAR SHOW & FLEA MARKET at Renningers Antique Center, Florida Twin Markets in Mount Dora on Rt. 441. Call Sid Trask 904-357-1614.
- 14 REGULAR MEMBERSHIP MEETING 7:00 pm at Sanford Motors Inc. (see address above). Cruise to Wendys after the meeting.
- 29 OAC Chapter Breakfast at 8:00 am. Frisch's Big Boy 605 Lee Road Orlando, Florida (just west of I-4)

HAPPY BIRTHDAY

SABRINA M.	CADE	1125
ROBERT A.	CADE	1119
GREGORY P.	CASE	1116
THELMA	CHAPMAN	1104
LEROY	GESSNER	1128
KEN	HARRELL	1107
LEROY M.	LONG	1116
MARTHA E.	MORRILL	1125
ALEXANDRA	MORRILL	1120
MICHELLE D	MYER (MYERS STUDEBAKER)	1120
CAROLYN	SWANSON	1116
DOROTHY	THOMAS	1126

Editors note:

The cover design was from memory of the pole barn visit Sunday morning at the State meet. It is a way of saying *thank you* for the delicious barbeque lunch, delightful tea party at the Cades, and banquet that had extra excitement because of the unusual door prize of the Mud Lark.

Everyone had a great time!

HAPPY ANNIVERSARY

TED & BEVERLY JANOWSKI	1126
DAVID & ROBERTA JOHNSTON	1103
RICHARD & MARJORIE LATCHAW	1127
FRED & SUE LAYMAN JR.	1130

Editor

Happy
Thanksgiving

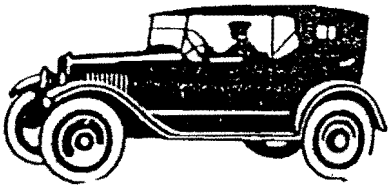

PRESIDENT'S

CORNER

The State Meet is now just a memory. I would like to thank everyone for their help and participation. All the effort great or small played a part in making this meet a success. Even the entrants did their part by bringing those beautiful cars for display. The weather did its part as well, no showers and not too hot. The Cade Family and friends I cannot thank enough for their time, effort, and financial support towards making this State Meet a most memorable event.

At one time there were 90 Studebakers on the grounds. John Ernst made the comment that, "This was like a International Meet back in the 70's." I hope that this will be a goal to meet or beat for the State Meets in the future.

We will be having some planned activities in the coming months so watch the Headlights section of the news letter for the dates of these activities. We are planning a Christmas Party on December 8th. Larry Golub, of the activities committee, has suggested a driving tour to St. Augustine while the weather is in the Studebaker Driving season. No date for the tour has been set as of this publication.

OAC MEMBERSHIP UPDATE

By Frank Ambrogio

As of November 3, 1991, 27 of the faithful have renewed their membership in the Orlando Area Chapter for 1992. I want to thank you for your promptness. It makes things a lot easier for me.

For anyone not planning to renew, this will be your last issue of Greasy Prints. We do not send out reminders as these have proven fruitless in the past. Should you change your mind, I hope you will keep your renewal form handy. We plan on being around for

some time and we are always happy to welcome back former members.

For the rest of you, please make your check payable to the Orlando Area Chapter - SDC and send it to me at the club address. We have had a few new members join since my last report and we also picked up a few new members at the State Meet in Gainesville.

Welcome to:

Bob & Beth Page Bradbury
4120 Rooster Ct. Sanford, Florida 32773
1952 Champion Custom 2 door sedan.

James Hugh & Alice Faye
Chance 374 Sage Rd. Winter Have, Florida 33881-9291
1957 Golden Hawk.

Noah & Versie Dancy Rt #7
Box 7480 Lake City, Florida 32055
1962 T-CAB, 1963 Daytona 2 door H.T., 1960 Lark 4 door, 1962 Lark Cruiser.

Don Dodgen 915 W. Concord Ave. Orlando, Florida 32805
1964 Daytona Conv. t.

Marvin & Cindy Evans 37212 Rolling Acres Rd. Lady Lake, Florida 32159
1938 Commander 4 door, 1952 Pick-up, 1956 Transstar Pick-up.
John F. & Linda C. Langley 188 Hermes Rd. Venice, Florida 34293
1948 Commander 2 door Coupe.

Bud & Pam Massey 65 Dolphin Blvd. Ponte Vedra Beach, Florida 32082
1950 Champion 4 door.

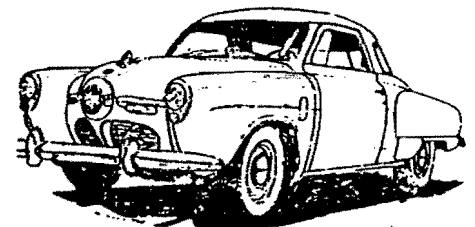
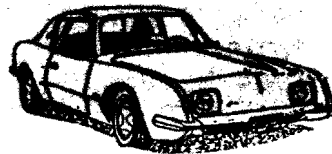

Studebaker

14TH ANNUAL FLORIDA STATE MEET
WINNERS

Class 1 Prewar - 1942
1st Place 1928 Erskine - Robert &
Mary Gade
2nd Place 1938 Commander Coupe -
Paul & Marion White

Class 2 1947 - 1952 (all)
1st Place 1950 Champion 4 door -
Dwight & Mabel Caler
2nd Place 1951 Commander State
Convertible - Bill & Shirley
Wecker

Class 3 1953 - 1955 Coupes and
Hardtops
1st Place 1953 Champion Starliner
- Earl Pasbach
2nd Place 1955 President Coupe -
Roy Hastings

Class 4 1953 - 1958 Sedans, Wagons
1st Place 1955 Commander 4 door -
Robert & Ethel Hillyard
2nd Place 1954 Connestoga Wagon -
Robert & Mary Gade

Class 5 1956 - 1961 Hawks & Hard-
tops
1st Place 1957 Golden Hawk - Don &
Donna McCullen
2nd Place 1957 Silver Hawk - Dave
& Roberta Johnston

Class 6 1959 - 1963 Larks
1st Place 1959 Lark 2 door - David
Walle
2nd Place 1959 Lark Regal Hardtop
- Rolfe Benson

Class 7 1962 - 1964 Gran Turismo
Hawks
1st Place 1964 GT Hawk - Ralph &
Phyllie Mathiot
2nd Place (tie) 1964 GT Hawk -
Larry & Barbara Golub
2nd Place (tie) 1964 GT Hawk -
Alberto & Olga Sanchez De Fuentes
Class 8 1964 - 1966 Studebakers
1st Place 1964 Daytona Convertible
- Dick & Tammy Long
2nd Place 1964 Wagonaire - Jim
Ricciardi

Class 9 1963 - 1964 Studebaker
Avanti
1st Place 1964 Avanti - Leonard
Wilson

Class 10 Commercial
1st Place 1964 Diesel Camper - John
& Gina Ernst
2nd Place 1950 Pickup - Tim & Celia
Bruekner

Class 11 Modified
1st Place 1934 Dictator - Jack
Brickles
2nd Place 1934 President - Ralph
Ivey

Class 12 1965 - 1991 Avanti II/
Avanti
1st Place 1984 Avanti - Dave Burton
2nd Place 1980 Avanti II - Geoff &
Myra Smith

Best of Show
1963 Avanti - Bill Amantia

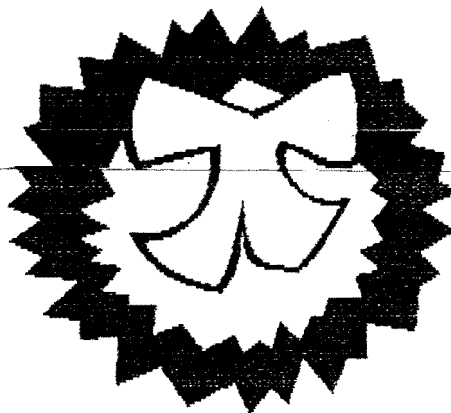

MERRY CHRISTMAS!!! YES, IT WILL BE
HERE SOONER THAN WE THINK. WE
HAVE MADE SOME PLANS FOR OUR ANNUAL
CHRISTMAS PARTY.

DATE: SUNDAY, DEC 8TH. TIME:
1:30 P.M. TENTATIVE LOCATION: BILL
KNAPP'S RESTAURANT, ON DOUGLAS AVE-
NUE (SOUTH OF HWY 434) IN LONGWOOD.

WE MUST HAVE A HEAD COUNT BY WEDNES-
DAY, DEC 4TH. CONTACT: LARRY OR BAR-
BARA GOLUB, (407) 788-0117.

PLACING A G.M. ALTERNATOR ON A STUDEBAKER GENERATOR BRACKET

(Courtesy of MISS OIL LEAK)

Want to put a typical General Motors Alternator onto a typical Studebaker generator bracket? Here's one good way. Use a standard SAE bolt the correct length to cross through the existing generator bracket and shim it to the alternator with a pipe cut to the correct length with a hacksaw. Your local Radio Shack carries a standard electrical plug to fit the alternator and splice into your existing wiring harness. Of course, you may use these diagrams to also connect in an original Studebaker-Prestolite alternator if your better judgement demands it!

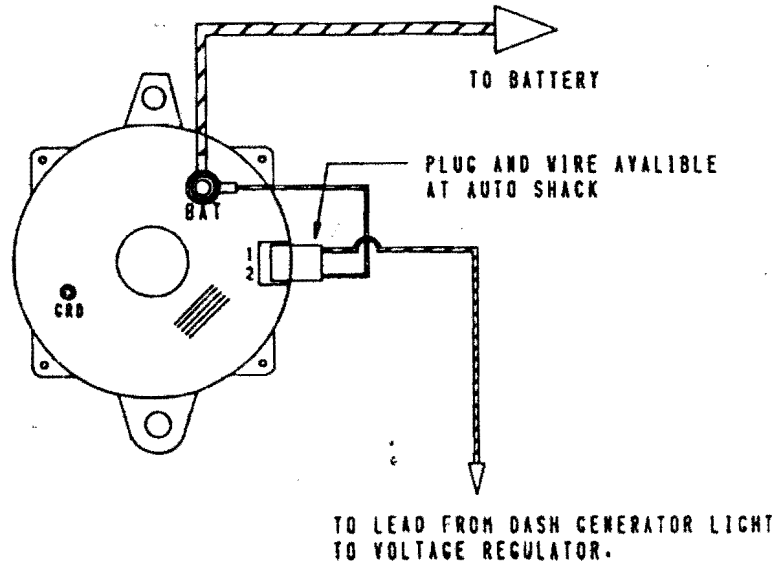
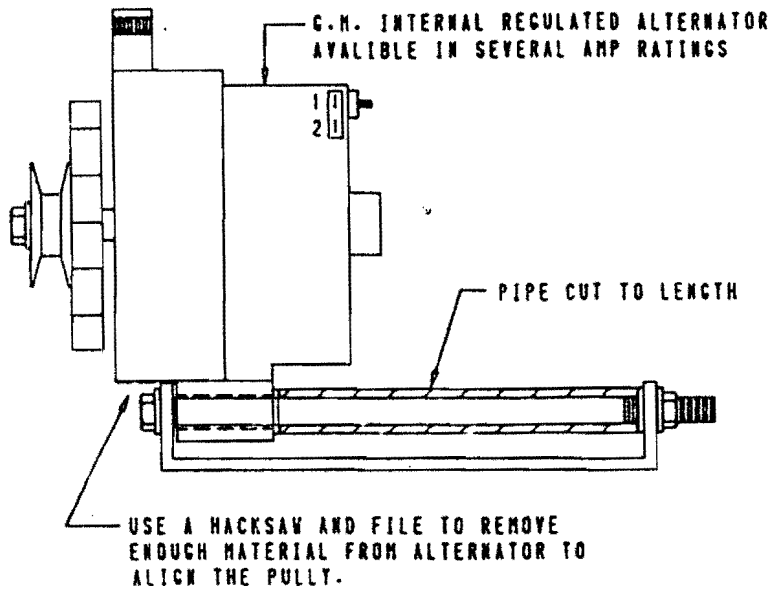

(THIS LEAD WILL HAVE APPROX. 10 VOLTS WITH THE IGNITION TURNED ON.)

Top Diagram Shows How Alternator Is Fitted To Existing Generator Bracket Atop Exhaust Manifold. Studebaker Had Bracket Alignment Problems Early In 1963, When They Went To Alternators. Late 1963 to 1964 Studebaker Alternator Brackets Would Be Direct Replacement.

EDITORIAL

CALL FOR ACTION

How would you like to have a senator or congressman tell you that your pristine '69 Chevelle big-block had to be either scrapped or never driven on the street again? Or how would you like the EPA (Environmental Protection Agency) to tell you that if you want to drive a car on public highways, it must be built after 1980? How would you like to be limited to a maximum number of miles driven with the allowed mileage based on the amount of pollution generated by the engine. How would you like your allowed mileage restricted even further by the amount of gas your car consumes per mile?

At a time when society at large is becoming increasingly more concerned about global warming, holes in the ozone layer, the depletion of natural resources, and good old smog, smaller sub-sets of society (meaning automobile enthusiasts) stand to lose. And it doesn't matter if you like Chevys, Fords, or Mopars.

Older cars are viewed by the "dogooders" as prime sources of pollution. And, quite frankly, many of them are. We've all seen plenty of mid-Seventies clunkers smoking down the road, leaving a telltale cloud of oil and/or unburned gasoline in their wake. And the sad fact is that even if you keep your '67 small-block Camaro in razor-sharp tune, the engine still pollutes significantly more than a '91 Camaro.

A variety of schemes have been proposed in order to rid the countryside of "clunkers." One popular plan that was proposed is to have the car manufacturers buy back older cars in exchange for the sale of a new or newer post-'80 car. For each "clunker" taken off the road, the car maker would receive credits towards its Corporate Average Fuel Economy (CAFE) requirements. Ironically, this plan could still allow the car makers to build "dirtier" new cars, however, credits from the "clunkers" would allow them to avoid any penalties. One obvious advantage to this plan would be the boom in new car sales, so don't expect car manufacturers or dealers to fight this proposal very strongly.

From June through October 1990, Unocal Oil paid \$700 each for more than 8000 pre-'71 cars and destroyed them. The company received a

tremendous amount of media attention for its efforts to "clean-up" the Southern California air. It was a major public relations victory for Unocal. What the company failed to mention was the fact the refinery wanted to get EPA emissions credits from the destroyed automobiles to help balance the emissions released by its San Pedro refinery.

As car enthusiasts, we need to be informed about any changes that effect us, and our voices need to be heard. Our numbers are far greater than the number of oil companies. If you're like me, you were thinking about cars during those high school civics classes. Now it's time for remedial civics. If everyone who owns a Chevy wrote to their congressmen, they'd listen. And if everyone else who drives an endangered species of car wrote, together the sum of our voices would be loud enough that our inherent right to own the car of our choice would never be jeopardized. The solution is simple: Get the addresses of your senator and congressman from the library and let them know where you stand. These people hold the reins of our future in their hands, and it's our responsibility to guide them along a route that benefits us.

SANFORD MOTOR CO., INC.

3418 S. Orlando Dr.
SANFORD, FLORIDA 32773



Cherokee - Comanche - Wrangler - Wagoneer - Premier - Medallion - Summit

DONALD J. BALES
President

Bus. Phone (407) 322-4382
Bus. Phone 321-0871

Paint & Body

Stainless Steel

Ted's
Classic Car Restorations

Ted Janowski
(904) 774-5512

2661 San Juan St.
DeLand, FL 32724



PACKARD FARM

Studebaker - Packard
Parts and Accessories
Large Inventory of Rubber Products
We Buy Toy Tractors

97 N. 150 W.
(Road 150 W. & U.S. 40)
Greenfield, IN 46140

BILL McDOWELL
(317) 462-3124

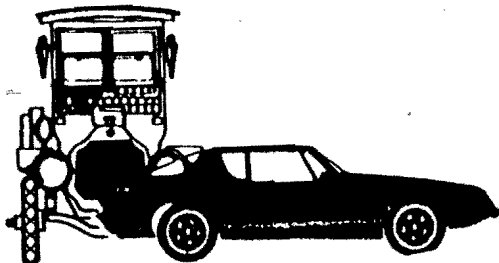

Larry R. Dudley

American
Speedy Printing
Maitland Center



(305) 682-5854

998 Lake Destiny Road
Altamonte Springs, FL 32714

AVANTI LARK HAWK
STUDEBAKER PARTS & REPAIR

R1
R2
R3
R4

SPECIALIZING IN
HARD TO GET PARTS
PERFORMANCE PARTS

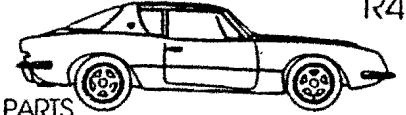

MYER'S STUDEBAKER PARTS
JON B. MYER
3842 BLEDSOE AVE.
LA, CA 90066

AOAI
SDC OEC
(213) 398-1947

Ed Reynolds
(213) 435-0157

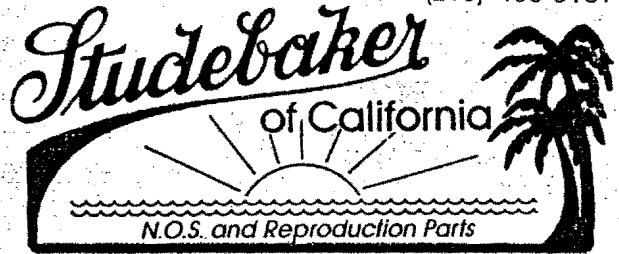

1400 Santa Fe Ave. Long Beach, CA 90813

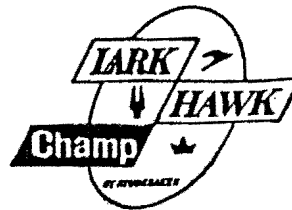

PHIL'S STUDEBAKER
818 Berlin
Mishawaka, IN 46544

(219) 255-3916

N.O.S. and Excellent Used Parts

Special Interest Autos of St. Louis, Inc.

PH. 314-279-1280

MAIL:
P.O. Box 944
ST. CHARLES, MO 63302

SHIPMENTS:
#5 CHALIN
ST. PETERS, MO 63376

HOURS: MON.-FRI. 8 A.M.-6 P.M.
SAT. 8 A.M.-NOON

Avanti

Avanti



Studebaker

THE STUDEBAKER DRIVERS CLUB ORLANDO AREA CHAPTER
MEMBERSHIP REGISTRATION FORM DUES \$10.00 PER YEAR (DUE AND RENEWABLE OCT 1)
(NEW MEMBERS, SEE SCHEDULE BELOW) MAKE CHECKS PAYABLE AND MAIL TO:
ORLANDO AREA CHAPTER - SDC 1025 NODDING PINES WAY CASSELBERRY, FL 32707

NAME _____ BIRTH DATE (MONTH/DAY) _____
 SPOUSE _____ BIRTH DATE (MONTH/DAY) _____
 ANNIVERSARY DATE (MONTH/DAY) _____

ADDRESS _____
 CITY _____ STATE _____ ZIP _____
 HOME PHONE _____ WORK PHONE _____

STUDEBAKER OR STUDEBAKER RELATED VEHICLES OWNED

YEAR	NAME	MODEL	BODY STYLE

NEW MEMBER DUES SCHEDULE (PAY AMOUNT INDICATED FOR THE MONTH YOU JOIN)

OCT - \$10.00 NOV - \$10.00 DEC - \$10.00 JAN - \$9.00 FEB - \$8.00 MAR - \$7.00
 APR - \$6.00 MAY - \$5.00 JUN - \$4.00 JUL - \$3.00 AUG - \$2.00 SEP - \$1.00

To join the ORLANDO AREA CHAPTER, you must be a member of the STUDEBAKER DRIVERS CLUB. Dues are \$18.00 per year. Send name, address, phone number to :

S.D.C. NATIONAL OFFICERS 1990-1991

President -	Terry Judd, P. O. Box 736, Grand Haven, Michigan 49417
Vice President -	Denny Lockman, 9331 Polk Street, Omaha, Nebraska 68127
Secretary -	Linda Costell, 6831 Balfour Road, Sylvania, Ohio 43560
Treasurer -	Colin D. Fort, P.O. Box 1204, La Jolla, California 92038

P.O. Box 28788, Dallas, Texas. 75122-0788. (1-800-527-3452)

The Studebaker Drivers Club, Inc.



Orlando Area Chapter
1002 Wild Lake Circle
Orlando, Florida 32765

AMBROGIO
 FRANK & ANITA AMBROGIO
 1025 NODDING PINES WAY
 CASSELBERRY, FL 32707

